

# Power quality improvement in microgrids using artificial intelligence techniques: A review

Shibin Shaji John , Heyrin Ann Sony, Lavanya V.\* , and Meera P.S.

School of Electrical Engineering, Vellore Institute of Technology, Chennai 600127, Tamil Nadu, India

Received: 1 September 2025 / Accepted: 13 March 2026

**Abstract.** The increasing adoption of Renewable Energy Sources (RES) is attributed to their sustainability, reduced environmental impact, and reliance on abundant natural resources. Microgrids are becoming more prevalent in existing power systems. The intermittent nature of renewable energy-based sources, as well as the integration of power electronic converters in these microgrids, leads to various power quality issues such as voltage and frequency fluctuations, current harmonics, transients, etc. To fully utilize the potential of renewable energy sources, these power quality issues must be addressed. This paper presents a comprehensive review of swarm-based and hybrid AI optimization techniques for improving the dynamic response and power quality in AC microgrid, analyzing over 100 relevant articles. The comparison of different algorithms is done in a systematic manner based on the speed of convergence, complexity of computation, capability of harmonic mitigation, and transient response. The major contribution of this paper is in understanding the limitations of individual swarm intelligence approaches and establishing the effectiveness of hybrid AI solutions. The results indicate that hybrid methods, especially ANFIS and PSO-ANN models, have better convergence speed, lower total harmonic distortion, and enhanced transient stability, which makes them more appropriate for power quality improvement in microgrids with renewable energy integration.

**Keywords:** Artificial intelligence, Microgrid, Optimization, Power quality, Renewable energy.

## Abbreviations

AC	Alternating Current
ACO	Ant Colony Optimization
AFBS	Adaptive Fuzzy Back Stepping
AFNN	Adaptive Fuzzy-Neural-Network
AFS	Adaptive Fuzzy Sliding
AI	Artificial Intelligence
ANFIS	Adaptive Neuro-Fuzzy Inference System
APF	Active Power Filters
BBO	Biogeography-Based Optimization
BFOA	Bacterial Foraging Optimization Algorithm
DG	Distributed Generation
DMLC	Dual Multilevel Converter
DVSI	Dual Voltage Source Inverter
DVR	Dynamic Voltage Restorer
EBFO	Enhanced Bacterial Foraging Optimization
ESS	Energy Storage System

FIR	Finite Impulse Response
FNN	Fuzzy Neural Network
FOPID	Fractional Order Proportional Integral Derivative
GA	Genetic Algorithm
GOA	Grasshopper Optimization Algorithm
GSA	Genetic Search Algorithm
GWO	Grey Wolf Optimization
HAPF	Hybrid Active Power Filter
HRES	Hybrid Renewable Energy System
HSHAPF	Hybrid Shunt Active Power Filter
IEA	International Energy Agency
ITAE	Integral Time Absolute Error
LFC	Load Frequency Control
LQR	Linear Quadratic Regulator
MCFNN	Meta-Cognitive Fuzzy Neural Network
MG	Microgrid
MPF	Modulated Power Filter
PEMFC	Polymer Electrolyte Membrane Fuel Cells
PCC	Point of Common Coupling
PI	Proportional Integral

\* Corresponding author: [lavanya.v@vit.ac.in](mailto:lavanya.v@vit.ac.in)

PQ	Power Quality
PR	Proportional Resonant
PSO	Particle Swarm Optimization
PSO-ANN	Particle Swarm Optimization-Artificial Neural Network
PV	Photovoltaic
PWM	Pulse Width Modulation
RES	Renewable Energy Sources
SAPF	Shunt Active Power Filter
SDG	Sustainable Development Goal
SDM	Synchronous Detection Method
SHF	Shunt Hybrid Filter
SI	Swarm Intelligence
SRF	Synchronous Reference Frame
SVPWM	Space Vector Pulse Width Modulation
THD	Total Harmonic Distortion
TSMC	Terminal Sliding Mode Control
UPQC	Unified Power Quality Conditioner
WOA	Whale Optimization Algorithm

## 1 Introduction

The rate of integration of Renewable Energy Sources (RES) is not adequate to address the global energy consumption rate. The International Energy Agency (IEA) has predicted an annual increase of 3.4% in global energy demand through 2026. To meet this demand, the electric power sector must be transformed into a smart, intelligent system with several Microgrids (MG) capable of supplying affordable and clean energy as per the United Nations Sustainable Development Goals (SDG 7) [1]. Microgrids are small, self-sufficient power networks that generate electricity for specific areas like university campuses, hospitals, military bases, or local communities. A microgrid comprises loads and micro-sources working together as a single controllable entity that can supply both heat and electricity to the local community [2]. A general AC Microgrid architecture is shown in Figure 1. The renewable energy-based sources, along with the Energy Storage Systems (ESS), are integrated into the AC MG with the help of suitable power converters/inverters to regulate the power flow in the system [3, 4]. Increased penetration of RES can give rise to various power quality disturbances like voltage sags, swells, notches, harmonics, transients, low power factors, noise, etc., as shown in Figure 2 [5].

Power Quality refers to maintaining the voltage and current waveforms near sinusoidal at the rated magnitude and frequency. Power Quality (PQ) disturbances, *i.e.*, deviations in the magnitude and frequency of the waveforms beyond the specified range, are more prominent when the MG operates in grid-connected mode. Usually, when the PQ disturbance is severe, the MG gets disconnected from the utility grid at the Point of Common Coupling (PCC), but it remains grid-connected if the disturbance is minimal. The disturbances accumulate on the utility side when there are multiple MGs operating in grid-connected mode, with each MG having minimal disturbance [6]. Most power quality issues are due to the nonlinearity of the connected loads [7].

The recent development in Artificial Intelligence (AI) has led to the concept of AI-based controllers for power quality improvement [8]. AI is generally defined as an automated system that replicates human intelligence, encompassing problem-solving, decision-making, perception, reasoning, and learning capabilities. Recent studies prove that AI-based controllers are superior to conventional control methods concerning robustness, stability, and response time. Figure 3 illustrates the various AI methods used in the literature to address the power quality issues in AC MG.

In this review paper, research on swarm intelligence and hybrid AI-based controllers used in different power conditioning devices is discussed. The merits and demerits of various optimization algorithms are also compared. The selection of articles in the specified research area is conducted using three primary online platforms, namely Google Scholar, Web of Science, and Scopus. To ensure a comprehensive review, relevant papers were considered in the timeframe between 2010 and 2025. Power quality improvement in microgrids, AI-based optimization methods in AC microgrids, hybrid AI optimization techniques, optimized control of frequency and voltage in autonomous AC microgrids, optimized dynamic response enhancement in AC microgrids, and traditional power quality mitigation strategies in AC microgrids employing swarm intelligence are the phrases used for selecting the relevant papers from the said platforms. The selected papers were prioritized based on journal quality, impact factor, Scopus indexing, and the type of conference. The primary criterion for the literature review was “power quality and dynamic response improvement in AC microgrids through AI-based optimization and hybrid AI techniques for power quality mitigation”. A framework for the review was developed after a comprehensive study and analysis of the selected papers.

The traditional compensation methods like passive filters, APFs, UPQC, and D-STATCOMs usually employ fixed parameter control and lack adaptability during dynamic and nonlinear operation, thereby making them inadequate for renewable-rich microgrids. As a result, intelligent optimization control methods have attracted interest due to their potential for offering adaptive, fast, and robust compensation [9–11]. In this regard, swarm intelligence and hybrid AI methods have been identified as promising alternatives; however, their relative efficacy, scalability, and applicability are scattered throughout the literature. Thus, a comprehensive review and comparison of the AI-based methods is necessary to determine their merits, demerits, and feasibility for ensuring improved dynamic performance and superior power quality in AC microgrid systems.

The remaining part of the paper is organized as follows: Section 2 describes the details of Power Quality Mitigation Techniques. Section 3 gives the insights into AI-based optimization techniques used for optimizing the parameters of APF, UPQC, and other controllers used for power quality improvement in AC microgrid systems. Section 4 details the hybrid AI techniques addressing power quality issues and the comparison of different methods used for power quality improvement. Section 5 provides the conclusion.

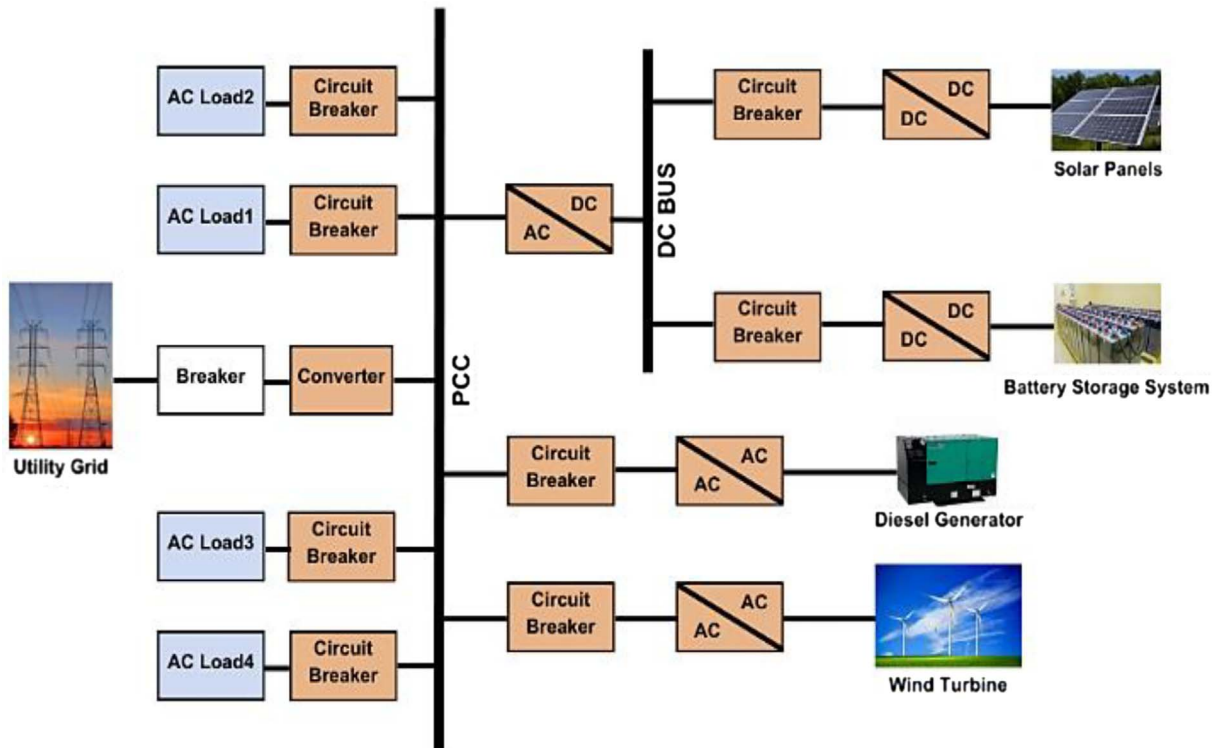

Figure 1. Structure of AC microgrid.

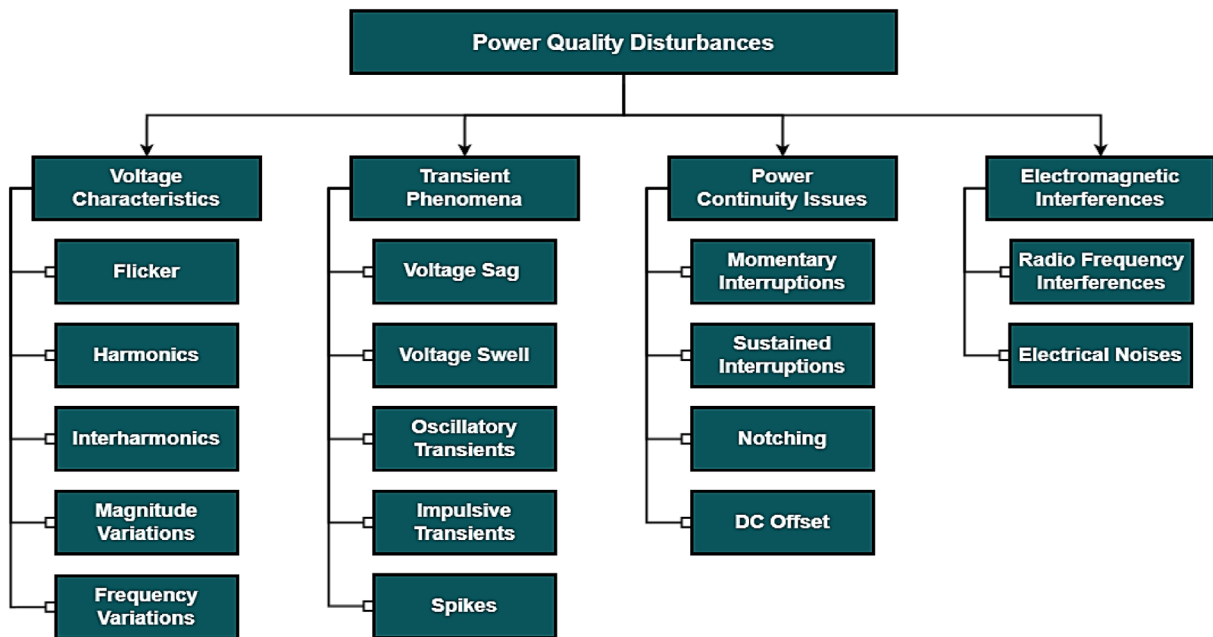
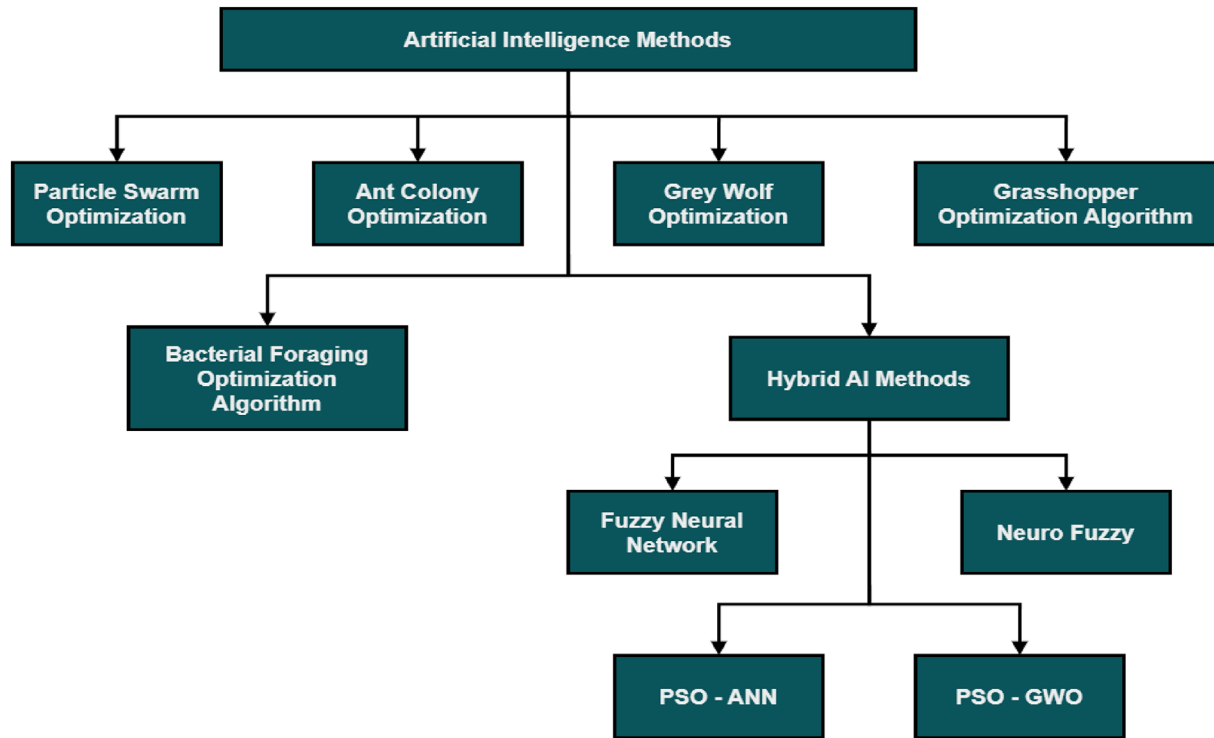

Figure 2. Power quality disturbances.

## 2 Overview of power quality mitigation techniques

Several custom power devices and active compensation techniques have been developed targeting specific PQ

disturbances at the distribution and transmission levels. Among them, the most widely adopted solutions are Active Power Filters (APFs), Dynamic Voltage Restorers (DVRs), Distribution Static Compensators (DSTAT-COMs), and Unified Power Quality Conditioners (UPQCs).



**Figure 3.** Various AI techniques used for power quality improvement.

Active power filters (APF), when adequately managed, are capable of compensating various power quality disturbances like current harmonics, voltage fluctuations, and unbalances [12–16]. APF is recognized as one of the most proficient compensators for effectively eliminating harmonics. The development of several active power filter configurations and their studies have been carried out in the recent past for mitigating harmonics and reactive power compensation when non-linear loads are present in the system [17–23]. APFs utilize power electronic converters to produce compensatory current to cancel out the harmonic currents caused by non-linear loads. The circuit can be designed in various configurations, namely, parallel, series, or hybrid, based on the type of interfacing inductor or transformer employed [24].

APF suppresses the reactive power as well as the current harmonics at the input side. Moreover, the performance of APFs remains unaffected by the characteristics of the power distribution system [25, 26]. However, active power filters are not fully effective in compensating for the detrimental effects of heavy loads with significant fluctuations. Additionally, they cannot completely mitigate all harmonics and voltage unbalances [27]. SAPF is an APF that is connected in parallel with the load. To address current harmonics, the system introduces a compensating harmonic current that matches the magnitude of the existing harmonic current but is phase-shifted by  $180^\circ$ . This effectively neutralizes the harmonic current, resulting in a grid current that is almost sinusoidal and synchronized with the source [28].

A Dynamic Voltage Restorer (DVR) is a series-connected custom power device designed to safeguard sensitive loads against voltage disturbances such as sags, swells, flicker, and short-term interruptions in a distribution network. The device works by injecting a controlled compensating voltage via a series injection transformer to ensure the required voltage level on the load side, thus ensuring the continuous and stable operation of the critical load [29]. Generally, a DVR system comprises a voltage source inverter (VSI), a DC energy storage system, an injection transformer, filters, and a fast-response control system that senses the disturbances and provides the necessary switching commands.

A Distribution Static Synchronous Compensator (D-STATCOM) is a shunt-type custom power device that is employed in a distribution system to control voltage, correct reactive power, and solve current-related power quality problems like harmonics, unbalances, and flicker [11]. A D-STATCOM is normally made up of a voltage source inverter (VSI), DC energy storage capacitor, coupling transformer, and a high-speed control system that injects or absorbs reactive current at the point of common coupling (PCC) to control the voltage. By dynamically adjusting the magnitude and phase of the injected current, the D-STATCOM provides rapid response and superior performance compared to conventional capacitor banks or passive compensators.

The Unified Power Quality Conditioner (UPQC) or Universal Active Filter is a combination of series and shunt active filters. It is used to remove multiple power quality problems simultaneously. This is a multi-functional power

conditioner, designed to correct different voltage problems and ensure that the harmonic load currents do not affect the power system. It is also used to control the flow of power and thus protects the critical loads [30].

### 3 AI-based optimization techniques

Over the past decade, numerous optimization techniques have emerged. The most widely used techniques are nature-inspired approaches that replicate the behaviors of animals, physical phenomena, and evolutionary processes. The term “swarm” in swarm intelligence (SI) denotes a vast collection of decentralized, homogeneous agents that collaboratively operate to accomplish shared objectives. In this context, SI refers to an AI subfield that simulates the group behaviour of natural swarms found in social organisms such as fish schools, ant colonies, bacterial clusters, animal herds, and bird flocks [31]. As a nature-inspired population-based approach, the SI algorithms provide effective and efficient solutions to complex optimization problems. The following sections introduce some of the most commonly used swarm intelligence optimization techniques applied in the improvement of power quality in AC microgrids.

#### 3.1 Particle swarm optimization

Particle Swarm Optimization (PSO), proposed by Kennedy and Eberhart in 1995, is a nature-inspired optimization technique. This algorithm, inspired by the bird flocking and fish schooling behaviors, uses swarm intelligence and is a population-based stochastic optimization technique. PSO has been proven to be an effective algorithm for large-scale non-linear optimization problems [32]. The major advantage of this algorithm is its robustness against the scale and complexity of the problem, which ensures that the solution is effective regardless of the size and non-linear nature of the problem [33]. The performance analysis of the PSO algorithm is carried out by monitoring the path of individual particles as well as the swarm. The particles start their journey randomly, using their own experience as well as the experience of the swarm. It is also drawn to the locations of its own best position,  $X_{pbest}$ , and the current global best position  $X_{gbest}$  [34]. The flowchart for the algorithm is given in Figure 4, and its fundamental principles can be elucidated using the following three steps:

- (a) Determine each particle’s fitness value.
- (b) Update the best fitness value and positions of the particles locally and globally.
- (c) Restore each particle’s position and velocity.

$X_i = [x_{i1}, x_{i2}, \dots, x_{im}]$  represents the position vector and  $V_i = [v_{i1}, v_{i2}, \dots, v_{im}]$  represents the velocity vector in a particular dimensional search space. The PSO algorithm’s optimality depends on how each particle’s position and velocity are updated using the following equations (1)–(2) [35].

$$V_i^{k+1} = w \cdot V_i^k + c_1 \cdot r_1 \left[ X_{pbest}^k - X_i^k \right] + c_2 \cdot r_2 \left[ X_{gbest}^k - X_i^k \right]. \quad (1)$$

$$X_i^{k+1} = X_i^k + V_i^{k+1}. \quad (2)$$

where  $V_i^k$  and  $X_i^k$  are the particle’s velocity and position at iteration  $k$ , respectively, and  $i$  is the particle’s index. The values of the coefficients  $c_1$  and  $c_2$  are often between [0, 2], whereas the inertia constant  $w$  is frequently in the range [0, 1]. The random numbers  $r_1$  and  $r_2$  are produced for every velocity update.  $X_{gbest}$  and  $X_{pbest}$  represent the current global best position attained by the swarm and the current local best position attained by each particle based on its own best position, respectively. PSO-based converters and conditioners have been proven to reduce PQ issues, as discussed below.

#### 3.1.1 PSO-based controllers

Figure 5 illustrates the control architecture of a Unified Power Quality Conditioner (UPQC) integrated with artificial intelligence (AI)-based optimization techniques for enhanced power quality mitigation [36]. AI optimization techniques play a critical role in tuning the control parameters of both the PWM voltage controller and the hysteresis current controller. Kumar *et al.* [37] employed state vector modulation to enhance voltage stability in UPQC systems, mitigating voltage sags up to 7%. Analysis of the synchronous detection method (SDM) and instantaneous reactive power theory (P-Q theory) for shunt active power filter (SAPF) control reveals that UPQC can remove current harmonics and ensure a unity power factor. P-Q control has a faster response than the SDM, which removes current harmonics within one cycle, unlike the SDM, which takes 14 cycles [38]. The UPQC described in [39] is controlled by the voltage angle, and it effectively removes power quality problems, such as voltage swells up to 26% and sags up to 81%, with a low harmonic content in the compensator output. The UPQC performs well when the DC link capacitor supplies sufficient power. Most design methods described in the literature do not consider the effect of changes in the feeder or load impedance and harmonic disturbances in source voltages or load currents. This neglect makes it more difficult to compensate for system uncertainties, thus reducing the overall performance of UPQCs. To overcome this problem, a robust PSO-based feedback controller for UPQC is developed in [40]. The PSO-based controller has significant advantages over the LQR-based controller, especially when partial state feedback is considered. Simulation and experimental data reveal that the PSO-based controller achieves superior performance in reducing total harmonic distortion (THD). The PSO-based feedback controller limits the increase in THD to 32% compared to 55% with LQR when the load impedance is increased by 100%.

Conventional APFs are inadequate in effectively compensating for the detrimental effects of heavy loads with

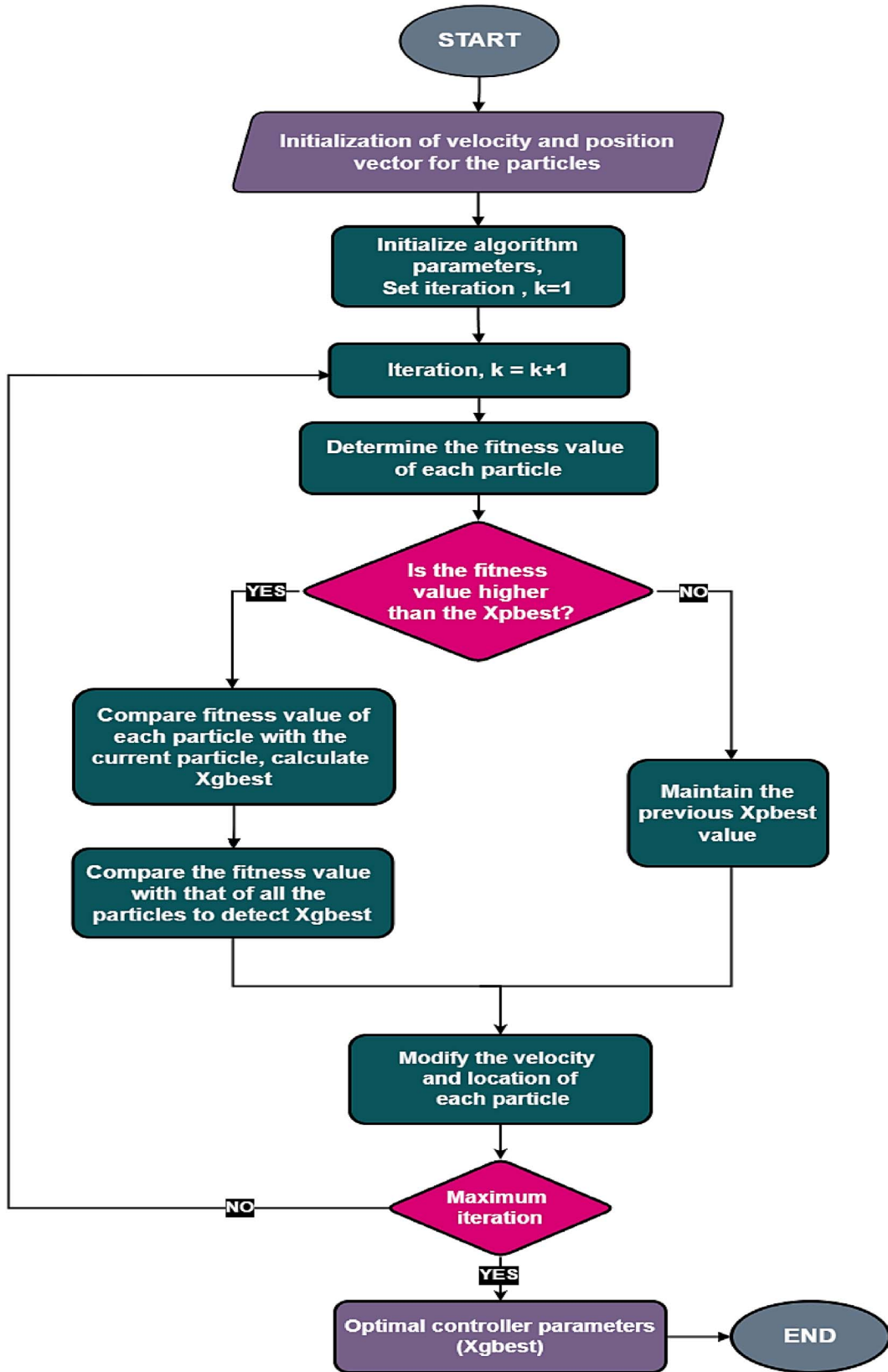
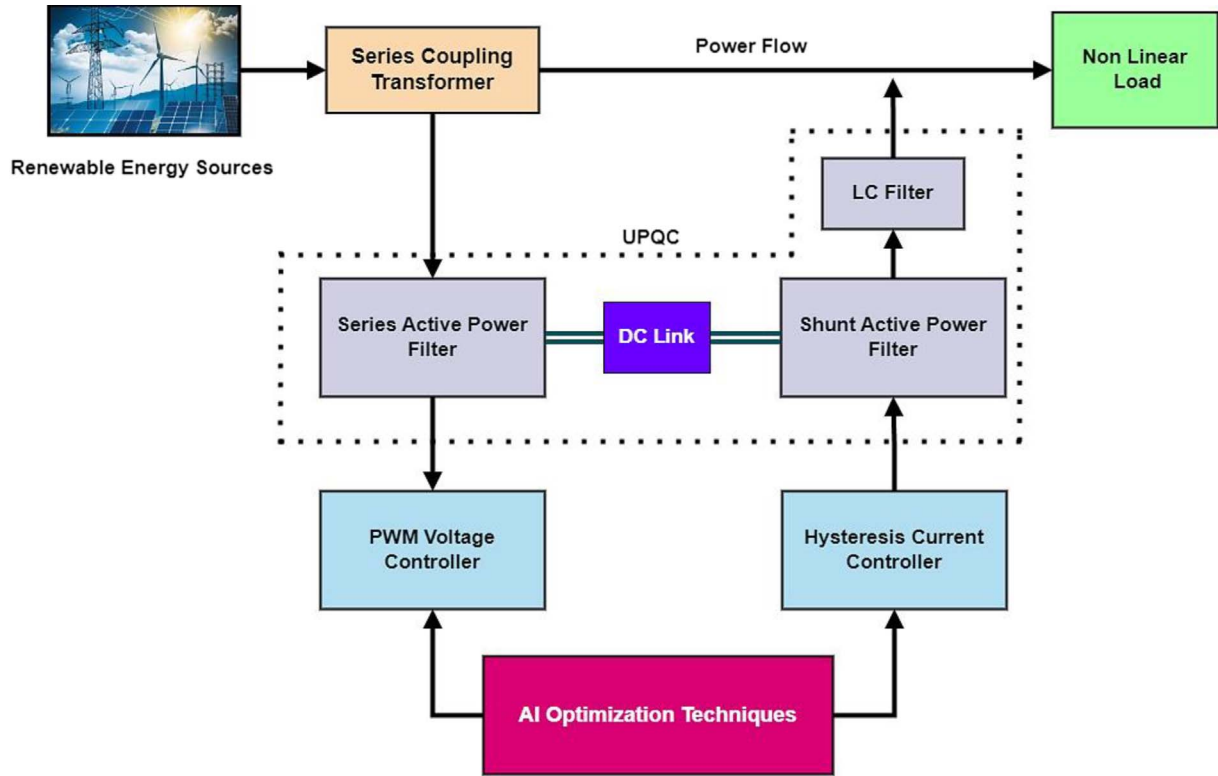

Figure 4. Particle swarm optimization algorithm.



**Figure 5.** Block diagram of UPQC with AI tuning.

significant fluctuations. It cannot address all harmonic distortions and voltage imbalances. The application of artificial intelligence-based controllers in APFs can address the above issues effectively. Current research in SAPF focuses on developing innovative control strategies for shunt active power filters and exploring new applications for these devices [41–53]. Although SAPF is known to reduce THD, it is not yet quite successful in doing the same under high-frequency conditions. Various improved versions of SAPF have been introduced in recent literature, including those based on PSO algorithms. A synchronous reference frame (SRF) theory-based SAPF is discussed in [54], where the gain values of the PI controller are optimized using PSO. The SAPF effectively eliminates harmonics, balances load, and regulates voltage without causing frequency deviations at the PCC under balanced, unbalanced, and nonlinear loading conditions. This PSO-based approach improved the power quality by reducing the THD from 23.90% to 4.01%.

### 3.2 Grey wolf optimization

The Grey Wolf Optimization (GWO) technique replicates the hunting tactics and leadership ranking characteristic of wolves [55]. The wolves can be classified into four groups: alpha, beta, delta, and omega. The three different phases in GWO are searching for the target, encircling the prey, and executing the attack [56]. The alpha wolves make decisions on hunting, shelter, and routines, with subordinates acknowledging their authority by lowering their tails,

indicating the pack's disciplined and organized structure. Subordinate wolves (Beta wolves) assist the alpha wolves in decision-making and group management and may succeed the alpha wolves if needed. They must respect the alpha wolves while holding authority over lower-ranking members and providing feedback. Delta wolves assume the role of scapegoats and are allowed to feed last due to the dominance of others. Despite their limited individual importance, their absence of disturbance maintains their position within the group, where they are occasionally referred to as babysitters. Omega wolves are the lowest in the hierarchy of wolves [57].

The mathematical representation of the hunting behavior of wolves provides the best solution to the alpha group, with beta and delta packs following, as illustrated in Figure 6. The flowchart of the grey wolf optimization algorithm is shown in Figure 7. The hunting behavior begins with encircling the prey, which can be expressed through equations (3)–(4).

$$\vec{D} = | \vec{c} \cdot \vec{X}_p(t) - \vec{X}(t) |, \quad (3)$$

$$\vec{X}(t+1) = \vec{X}_p(t) - \vec{A} \cdot \vec{D}, \quad (4)$$

where,  $t$  indicates the current iteration,  $\vec{A}$  and  $\vec{c}$  are random coefficient vectors calculated using the equations (5)–(7),  $\vec{X}_p$  refers to the position vector of the prey,  $\vec{X}$  is the location vector of grey wolves.

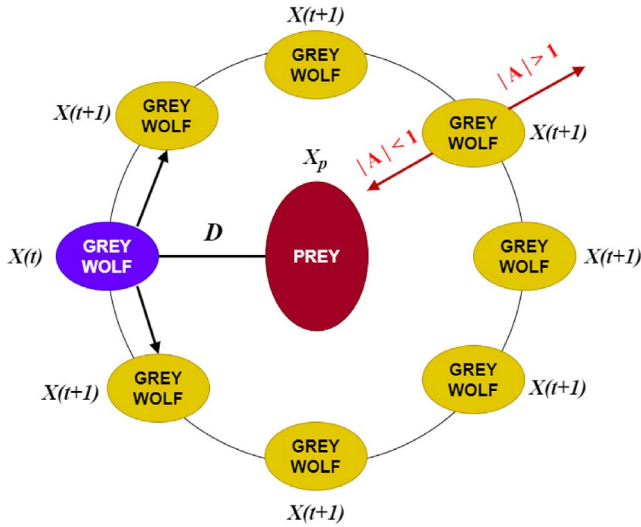

**Figure 6.** Representation of wolves' hunting process.

$$\vec{A} = 2\vec{a} \cdot \vec{r}_1 - \vec{a}, \quad (5)$$

$$\vec{c} = 2 \cdot \vec{r}_2, \quad (6)$$

$$\alpha = 2 \left( 1 - \frac{t}{N} \right), \quad (7)$$

where  $N$  is the maximum number of iterations. The value of  $i$  progressively reduces from 2 to 0. If  $|\vec{A}| > 1$ , omegas engage in a phenomenon known as the “global search,” in which they flee from dominants and/or prey. If  $|\vec{A}| < 1$ , omegas engage in a known as “local search,” following dominants as they get closer to the prey. The random vectors  $r_1$  and  $r_2$  vary between  $[0, 1]$  and they represent the wolves' random positions between their current and global positions. Alpha is the best candidate for leading the hunting process, followed by beta and delta, which are referred to as the best search agents. The positions of omegas are updated based on the positions of beta and delta. The target's position at iteration “ $t$ ” is assessed by the position of alpha, beta, and delta wolves given by the equation (8), while the omegas sporadically adjust their positions to encircle the prey.

$$\vec{X}(t+1) = \frac{\vec{X}_1 + \vec{X}_2 + \vec{X}_3}{3}, \quad (8)$$

where  $X_1$ ,  $X_2$ , and  $X_3$  represent the positions of alpha, beta, and delta wolves. The grey wolf optimization technique has been extensively applied to enhance the dynamic response and power quality of AC microgrids. A few of the research works related to MG control are analyzed in the following subsections.

### 3.2.1 GWO-based controllers

GWO is used along with a fractional order proportional integral derivative (FOPID) controller to improve the UPQC performance, thereby addressing the power quality

issues. The GWO algorithm exhibits several advantages, such as early convergence and optimized fitness values.

GWO outperforms several other algorithms, such as biogeography-based optimization (BBO), genetic algorithm (GA), and genetic search algorithm (GSA) in conjunction with the standard PI controller. The dynamic method proposed by Gupta *et al.* [58] employs a fractional order PI controller optimized through the GWO Technique. This approach has demonstrated an improvement in power quality by decreasing Total Harmonic Distortion (THD) as per the IEEE standard. Goud *et al.* [59] showed that a GWO-optimized FOPI controller combined with a shunt hybrid active power filter significantly lowered THD from 27.43% to 1.74%. Rajagopal *et al.* proposed a GWO-based PI controller for addressing the power quality issues and improving the system dynamics [60]. Ravi *et al.* [61] introduced a novel hybrid method combining the Stockwell transform and Kernel Extreme Learning Machine, optimized via GWO, for power quality disturbance detection and classification. Comparative results demonstrate its high accuracy, even in noisy conditions.

### 3.3 Ant colony-based optimisation

Ant colony optimisation (ACO) algorithms are modelled from the foraging pattern of ants, in which ants leave pheromones to mark the best path. This biological phenomenon is used in ACO to tackle complex optimisation problems by simulating the process of path selection based on pheromones [62]. Ants have a natural capability to find the shortest path to the food source by leaving pheromone trails to guide other ants. Ants tend to move along the path with a higher concentration of pheromones, which reinforces that path as the best one. This phenomenon is mimicked in optimisation algorithms, in which multiple agents work together to reach the optimal solution. The major advantage of ACO algorithms is their capability to efficiently cluster data and create optimal paths. The process of laying pheromones, which is essential for ant-based communication, is both time-consuming and inefficient. Additionally, this approach is susceptible to the risk of becoming trapped in local optima, which can hinder the overall solution quality. There are three main components to the ant colony search mechanism, mainly the initialization phase, the transition rule, and the pheromone trail updating rule, as shown in Figure 8 [63].

In the initialization process, crucial parameters like ant number, pheromone trail relevance, visibility weight, initial pheromone levels, deposition constant, evaporation rate, and tuning factors need to be set and accurately managed. For an ACO model, the transition probability for the  $k$ th and from state  $i$  to state  $j$  is given by equation (9).

$$P_{ij(k)}(t) = \begin{cases} \frac{[\tau_{ij}(t)]^\alpha [\eta_{ij}(t)]^\beta}{\sum_{j \in N_i^{(k)}} [\tau_{ik}(t)]^\alpha [\eta_{ik}(t)]^\beta}, & j \in N_{i(k)} \\ 0, & j \notin N_{i(k)} \end{cases}, \quad (9)$$

where  $\tau_{ij}$  is the trail intensity on edge  $(i, j)$ ,  $\eta_{ij} = \left( \frac{1}{c_{ij}} \right)$  is called the heuristic function,  $\alpha$  is the pheromone weighting factor,  $\eta_{ij}$  is the heuristic value on arc  $ij$ ,  $\beta$  is the heuristic

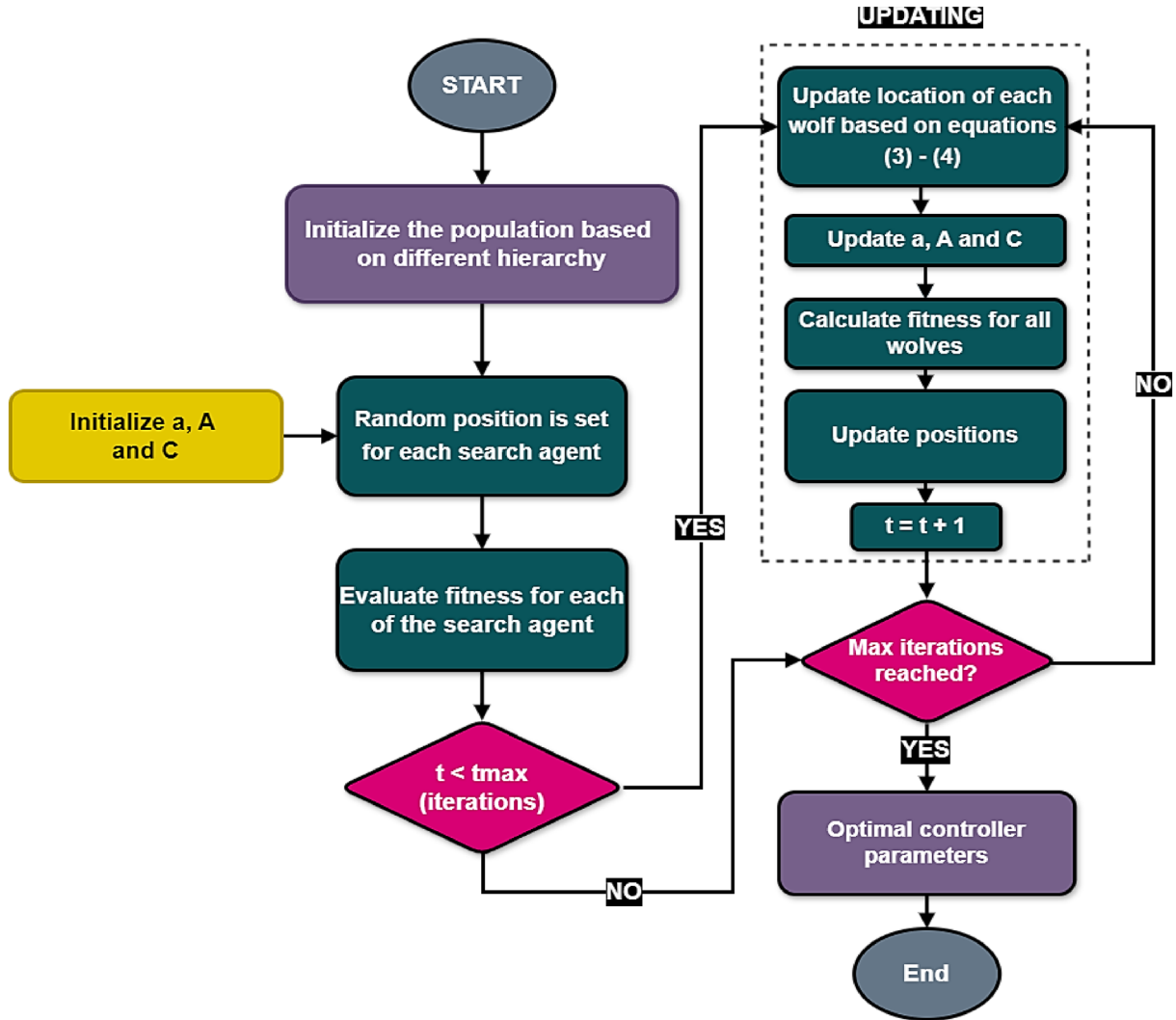

Figure 7. Grey wolf optimization algorithm.

weighting factor,  $N_i$  is the feasible neighborhood of options for the ant,  $k$ , to traverse from node  $i$ . The agent modifies the pheromone concentration on the visited path using a local update strategy as given in equation (10).

$$\tau_{ij} = (1 - \zeta)\tau_{ij} + \tau_0, \quad (10)$$

where  $\zeta$  is the heuristically defined parameter, and  $\tau_0$  is the initial pheromone level. The desired path is adjusted dynamically based on the pheromone data. The global pheromone updating rule, as given in equation (11), is applied after all agents have built their solutions. This encourages more pheromones on frequently used paths.

$$\tau_{ij} = (1 - \rho)\tau_{ij} + \Delta \tau_{ij} \quad (11)$$

where  $\rho$  is the pheromone decay factor ( $0 < \rho < 1$ ).

### 3.3.1 ACO-based controllers

The flexible and scalable characteristics of ACO make it capable of functioning at its best in different microgrid

operating conditions, thereby dealing with voltage problems such as sag, swell, and so on, resulting in a decrease in THD and an improvement in power quality.

Benachaiba *et al.* [29] introduced a new method for the control of a dynamic voltage restorer (DVR) using an ACO-based PI controller (ACOPI). The simulation outcome shows that the ACOPI controller enhances the response time and control accuracy and stability better than the traditional PI controller. This clearly indicates the effectiveness of the ACO method in enhancing the control strategy of the DVR. The proposed method provides a significant advantage by stabilizing the DC voltage faster in the presence of voltage disturbances. The use of ACO has been found to be effective in reducing disturbances caused by sags and swells, thus improving power quality more efficiently than the traditional PI controller.

APFs inject harmonic components to neutralize those in the load current and are commonly connected at the PCC to compensate for multiple loads. Among them, voltage source PWM inverter-based SAPFs are favoured due to their superior efficiency compared to current source

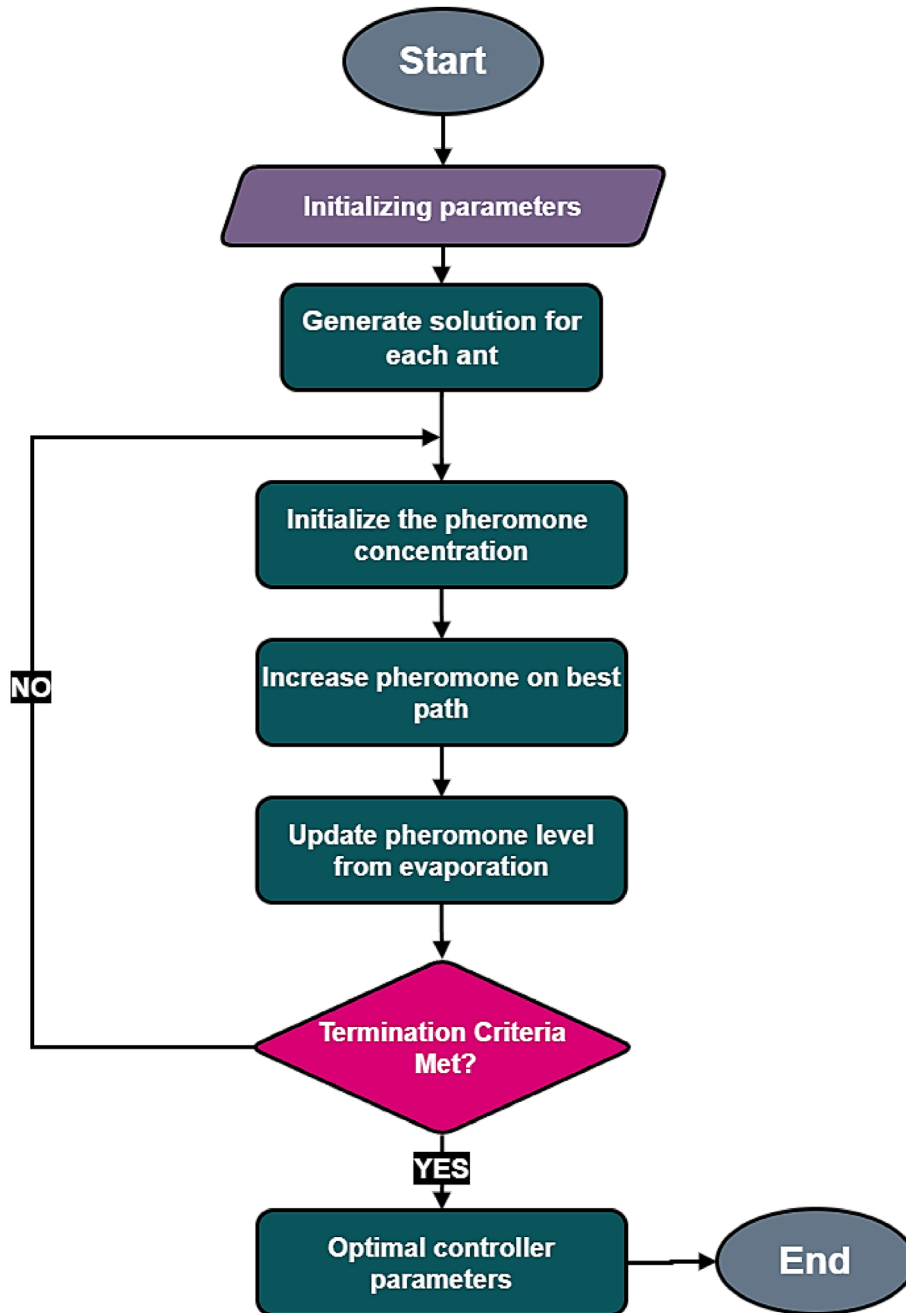

**Figure 8.** Ant colony optimization algorithm.

inverters [64–66]. The performance of SAPF is primarily influenced by the selected reference generation scheme, the reference signal being the key to its operation. The signal processed by the PI controller ensures that SAPF functions correctly. There are multiple techniques for determining the reference switching current for the APF [67]. Various algorithms that are being used to tune the parameters of the PI controller are not capable of adequately capturing the dynamic response of the controller, as they consider only the isolated characteristics of the DC bus voltage. ACO is used to optimize PI controller

gains in a Shunt Active Power Filter (SAPF) for improved dynamic performance [68].

The ACO-optimized PI controller resulted in a substantial improvement in the response of the DC bus voltage for varying loads, with a settling time reduction of over 9 times for the increasing load and 13.5 times for the decreasing load compared to the conventional controller. The proposed approach is found to be robust and efficient for improving the SAPF performance and power quality. Hybrid active power filters (HAPF) are a combination of passive and active filters, providing a balanced solution for harmonic

suppression and voltage control. This topology takes advantage of the economic viability of passive filters and the superior performance of APFs, providing an optimal solution for enhancing the power system stability [9, 69]. Tiwari *et al.* [70] present an ACO-based approach for the design of HAPF to satisfy the design requirements. The proposed approach optimizes the filter parameters simultaneously, which is an advantage in filter design. The results show that the designed filter satisfies the specified requirements, providing better performance and a reduced structure.

Moreover, the ACO-based method is flexible and can be used for the optimization of interlaced filters with multiple passbands. By employing this technique, the THD value was decreased from 30% to 3.87%, thus leading to a substantial improvement in the power quality. Kumarasabapathy *et al.* [10] present a fuzzy logic control technique for the UPQC to counteract voltage sag and total harmonic distortion, thus enhancing the power quality in the distribution network. The control technique employs a fuzzy logic controller to produce the required reference signals, and the fuzzy membership functions are tuned using ACO. The results validate the effectiveness of the proposed technique in enhancing the overall power quality. On comparing, the THD value without UPQC is 4.17%, whereas the THD value with the ACO-FLC controller is obtained as 0.13%.

### 3.4 Grasshopper optimization algorithm

The Grasshopper Optimization Algorithm (GOA) is a new development in SI proposed by Saremi and Mirjalili in 2017, inspired by the swarming behavior of grasshoppers. The algorithm utilizes the dynamic behavior of grasshoppers to improve its problem-solving abilities in different optimization problems [71]. Known for their capacity to inflict substantial damage on crops, grasshoppers are widely acknowledged as harmful pests in agricultural settings [72]. Grasshoppers undergo a life cycle consisting of two main stages: nymph and adulthood. During the nymph stage, their movements are limited and gradual, while in adulthood, they exhibit long-range and abrupt movements. These stages reflect the intensification and diversification phases of GOA.

The parameters of the PI controller used with Distributed Static Synchronous Compensator (DSTATCOM) are tuned using GOA, thus improving the sinusoidal nature of voltage and current waveforms at PCC [11]. GOA has been successfully implemented in the development of various inverters, as in the case of selective harmonic elimination in a low-frequency voltage source inverter [73] and filters, as in the case of optimal design of a digital FIR filter [74]. GOA is used to optimize the parameters of the static synchronous series compensator controller [75], to optimize the PI controller for improving the performance of a grid-connected wind generator [76], to tune the parameters of the PID controller for the LFC of an autonomous two-area hybrid microgrid [77], and various other applications. GOA has been proven successful in improving power quality because of its ability to be integrated with controllers for adaptive tuning. Mathematical models of the grasshoppers' swarming behavior are given in equations (12)–(15).

$$X_i + S_i + G_i + A_i, \quad (12)$$

where the position of the  $i$ th grasshopper ( $X_i$ ), its social interaction ( $S_i$ ), gravitational force ( $G_i$ ), and wind advection ( $A_i$ ) are the key parameters. To introduce stochastic elements into the grasshopper behaviour, equation (12) is modified to equation (13).

$$X_i = r_1 S_i + r_2 G_i + r_3 A_i, \quad (13)$$

where  $r_1$ ,  $r_2$ , and  $r_3$  are random numbers in the range [0, 1]. To solve complex optimization problems and circumvent local optima, equation (14) is used.

$$X_{id} = C \left( \sum_{j=1}^N c \frac{ub_d - lb_d}{2} S \left( \left| x_j^d - x_i^d \right| \right) \frac{x_j - x_i}{d_{ij}} \right) + \hat{T}_d, \quad (14)$$

where  $ub_d$  and  $lb_d$  indicate the upper and lower boundaries of the  $d$ th dimension, respectively.  $ub_d$  is the dimension value in the best current solution, while  $c$  serves as a decreasing coefficient to limit the comfort, repulsion, and attraction ranges. To balance exploration and exploitation in the search for the optimal solution, the parameter  $c$  decreases proportionally with the number of iterations as given in equation (15). This adjustment promotes more exploitation as the number of iterations increases by narrowing the comfort zone based on the number of iterations

$$c = c_{max} - l \frac{c_{max} - c_{min}}{L}, \quad (15)$$

where  $c_{max}$  and  $c_{min}$  denote the upper and lower limits,  $l$  refers to the current iteration, and  $L$  is the specified maximum number of iterations.

#### 3.4.1 GOA-based controllers

Jumani *et al.* [78] present an intelligent power flow controller using GOA specifically designed for grid-connected microgrid systems. The main objective of the research work was to optimize the active and reactive power exchange between the microgrid and the utility grid, ensuring that the overshoot is minimized, the settling time is reduced, and the total harmonic distortion is reduced, especially when the microgrid is highly penetrated with DG. The power quality analysis of the microgrid system used in the study reveals that the proposed controller satisfies the power quality standards as specified in IEEE Standard 929-2000, ensuring distortion-free power supply to the load. Elmetwaly *et al.* [79] proposed an adaptive switched filter compensator (ASFC) using a GOA/PID controller to find the optimal gains and minimize the error. The simulation outcome reveals a significant improvement of 94% in THD using the ASFC, whereas the modified D-STATCOM and conventional SFC showed improvements of 50.6% and 80.2%, respectively. This clearly indicates the potential of GOA in improving power quality in microgrids. Mustafa *et al.* [80] use GOA to find the optimal values of PI controllers in an islanded microgrid system. The simulation results validate that GOA outperforms PSO and Whale Optimization Algorithm (WOA) in achieving a faster and

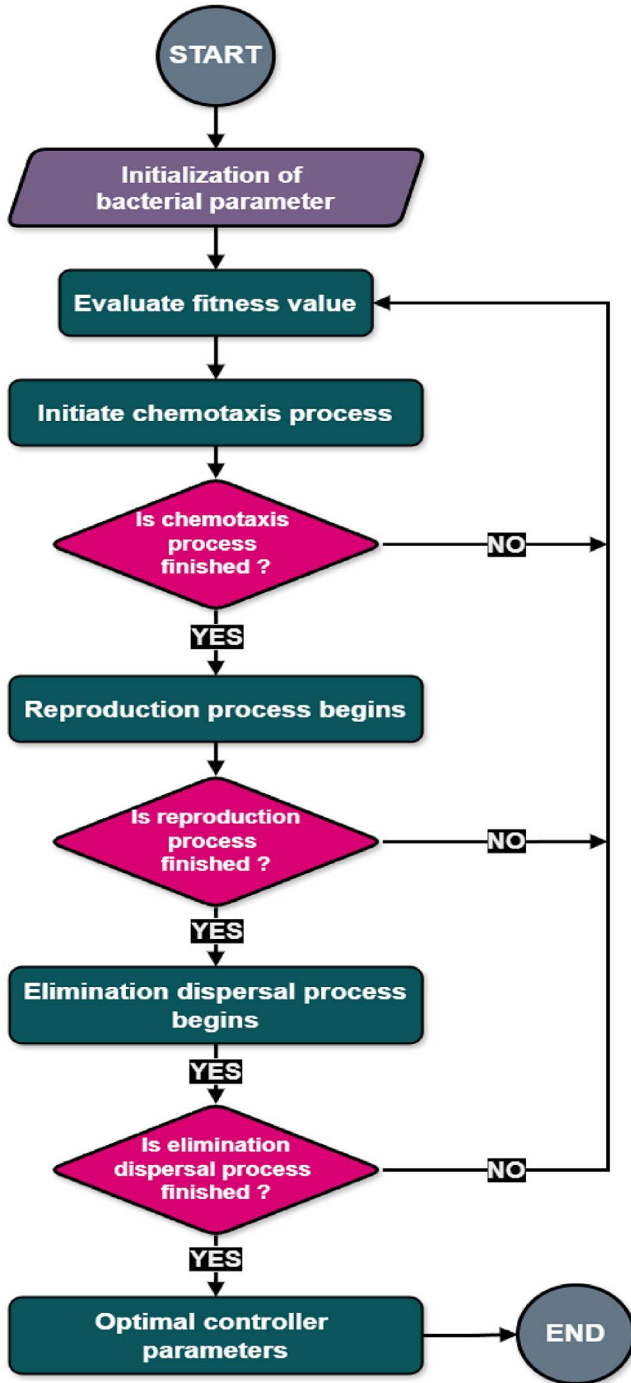

Figure 9. Bacterial foraging optimization algorithm.

better solution, which results in the minimization of voltage and frequency overshoot, as well as THD. The convergence of the controller was enhanced by 23.81% and 33.33%, respectively, compared to PSO and WOA-based controllers.

Abdulwahab *et al.* [81] used a droop controller to reduce the variations occurring during the islanding and load changes. To accomplish this, the controller parameters are

optimized using GOA, which ensures stability during the disturbances. The simulation results show that the frequency variation, immediately after switching the microgrid to island mode, is significantly lower (0.0036%) using the GOA-optimized droop controller than that of the GA-optimized droop controller (0.2140%), thus improving the power quality.

### 3.5 Bacterial foraging optimization algorithm

The Bacterial Foraging Optimization Algorithm (BFOA), developed by Passino, is a new entrant in the family of nature-inspired optimization algorithms. The innovative method, inspired by the foraging behavior of bacteria, provides a distinct approach in the general area of evolutionary algorithms [82]. The BFOA algorithm draws inspiration from the social behavior of *Escherichia coli* bacteria. Bacteria, in their search for food, try to maximize their energy return per unit time and interact with each other through a signaling process. This decision-making process, based on chemotaxis, where bacteria move in a stepwise fashion to reach the food source, is the inspiration for the basic idea of the algorithm [83].

BFOA performs very well in a particular domain, especially when combined with other algorithms. But its dependence on the problem structure and the absence of systematic tuning procedures make it less generalizable and may require major modifications for different optimization problems. Various modifications of BFOA are introduced to overcome these limitations. Some of the most popular ones are chemotactic differential evolution [84], in which BFOA was hybridized with differential evolution, bacterial swarm optimization [85], in which BFOA was integrated with PSO, etc. The BFOA technique involves four main steps: chemotaxis, swarming, reproduction, and elimination-dispersal, as shown in Figure 9. Chemotaxis emulates the behavior of an *E. coli* bacterium, involving swimming and tumbling facilitated by its flagella. The bacterium's movement in chemotaxis is represented by the equation (16).

$$\theta^i(j+1, k, l) = \theta^i(j, k, l) + C(i) \frac{\Delta(i)}{\sqrt{\Delta^T(i)\Delta(i)}}, \quad (16)$$

where  $\theta^i(j, k, l)$  is the location of the  $i$ th bacterium at the  $j$ th chemotactic,  $k$ th reproductive, and  $l$ th elimination-dispersal phases, with  $C(i)$  indicating the step size in a randomly chosen direction (run length unit), and  $\Delta$  represents a vector with randomly directed elements, each within  $[-1, 1]$ .

#### 3.5.1 BFOA-based controllers

Various researchers have employed BFOA to improve the power quality of the grid. Chitra *et al.* proposed a new power control approach based on BFOA for autonomous microgrid applications [86]. The approach integrates two control loops, where the inner control loop uses a current controller designed in a synchronous reference frame, and the outer control loop uses a power controller with conventional PI controllers.

**Table 1.** Comparison of various AI techniques used for power quality improvement.

Attributes	AI optimization techniques				
	PSO	ACO	GWO	GOA	BFOA
Influence	Inspired by the social behavior of birds and fish.	Inspired by ant foraging behavior.	Inspired by the social and hunting behavior of grey wolves.	Mimics grasshopper movements during food search.	Incorporates chemotaxis, swarming, reproduction, and elimination-dispersal of bacteria.
Complexity	Low complexity, ~50–100 iterations, fast execution (~0.5–2 s)	Moderate complexity, ~100–200 iterations, runtime (~2–5 s) due to pheromone updates	Low to moderate complexity, ~80–150 iterations, runtime (~1–3 s)	Moderate complexity, balances exploration and exploitation, ~100–200 iterations	High complexity, ~200–500 iterations, longer runtime (~5–10 s) due to multiple simulation stages
Suitability	Effective in handling non-linear and multiobjective optimization.	Suitable for solving combinatorial and routing problems.	Ideal for nonlinear and optimization challenges.	Suitable for dynamic and nonlinear optimization problems.	Suitable for multiobjective and complex optimization problems.
Convergence	Provides fast convergence with moderate computational time.	Produces high-quality solutions.	Maintains a strong balance between exploration and exploitation.	Exhibits rapid convergence under favorable conditions.	Explores solution space extensively.
Limitations	Prone to local optima while handling high-dimensional, intricate situations.	Requires significant computational time and resources.	Requires parameter adjustments for best performance.	Prone to instability in highly dynamic scenarios.	Requires high computational resources and converges slowly.
Parameter Sensitivity	Needs precise parameter adjustment.	Risk of pheromone path stagnation.	Efficiency may diminish in very high-dimensional spaces.	Requires thorough parameter tuning.	Resource-intensive for large-scale systems.

Upon the microgrid's transition to island mode, the voltage-frequency control mode is activated to ensure that the voltage and frequency values are within the desired range. The PQ control approach is used to handle the dynamic changes in the loads in an autonomous microgrid. Upon the microgrid's transition to autonomous mode or a change in the load, the BFOA algorithm enables real-time self-tuning of control parameters to improve power quality. Simulation results show that the proposed power controller provides a superior performance in maintaining voltage and frequency stability in autonomous mode [87].

Othman *et al.* introduced modulated power filters (MPF) to be incorporated within a microgrid environment to realize substantial technical advantages like optimized voltage profiles, effective energy use, optimized control strategies, and improved power quality. An improved bacterial foraging optimization (EBFO) algorithm is used to

optimize the control gains of a tri-loop PI controller in the MPF structure to reduce the absolute value of the global error signal. Digital simulation results validated the efficacy of the MPF structure in improving the power quality and voltage profiles [88].

Dubuisson *et al.* investigated predictive control based on BFOA for standalone microgrid systems, concentrating on a two-level system that controls the DC-link voltage, grid voltage, and grid frequency. The reference power signal from the BFOA is used as an input to the predictive control strategy on the AC side, thus optimizing power interactions and improving power quality at the PCC [89].

Tang *et al.* proposed a dynamic BFOA to solve the optimal power flow problem considering the variation of loads. The proposed method was applied to the conventional IEEE 30-bus and 118-bus test systems to optimize the fuel cost of power systems using the optimal power flow solution

**Table 2.** Performance analysis of various hybrid AI techniques.

Attributes	Hybrid-AI optimization techniques			
	FNN	ANFIS	PSO-ANN	PSO-GWO
Influence	Combines human reasoning with neural learning.	Combines neural networks for learning and fuzzy logic for decision making.	Based on the social behavior of bird flocking and fish schooling.	Integrates the social hierarchy of wolves with exploratory strategies.
Convergence	Fast convergence, enabled by learning and adaptability.	Fast convergence is achieved through adaptive mechanisms.	Performance is moderate and influenced by initial parameter choices.	Rapidly balances exploration and exploitation.
Computational time	Moderate	Moderate	Low	Low to Moderate
Scalability	Highly adaptable to problems of different sizes and complexities.	Highly suitable for a wide range of applications with excellent scalability.	Suitable for medium-sized problems with limited scalability.	Highly scalable for large and complex problem domains.
Robustness	Strong resistance to environmental noise and uncertainties	Very high adaptability to fluctuating environments.	Highly capable of managing data and variations in parameters.	Very effective in handling varied conditions and scenarios.
Real-time hardware functionality	Good	Very Good	Average	Very Good

structure for different loading conditions. The outcome of the study shows that the BFOA method performs well by rapidly responding to the changes in the loads, thus enhancing the PQ significantly [90]. The comparison of different AI techniques used for power quality improvement is shown in Table 1.

The optimization algorithms – PSO, ACO, GWO, GOA, and BFOA – have unique properties in terms of computational complexity, convergence rate, and problem type as mentioned in Table 1. PSO, developed based on the social foraging behavior of birds and fish, has low computational cost and fast convergence speed, making it efficient for linear and multiobjective optimization problems, but its property of easy premature convergence makes it less effective for high-dimensional search spaces. ACO, developed based on the foraging behavior of ants, has a higher computational cost due to the pheromone update rules, but it is highly effective for combinatorial and routing problems, as it always produces high-quality solutions. GWO, developed based on the social hierarchy and hunting strategy of grey wolves, has a moderate computational cost and a good exploration-exploitation trade-off, making it effective for non-linear optimization problems, but its efficiency decreases with the increase in dimensionality. GOA, developed based on the grasshopper social foraging behavior, has high sensitivity to parameter settings and dynamic environments, but it has the potential to converge quickly if favourable conditions are met. BFOA, developed based on the chemotaxis, reproduction, and elimination-dispersal processes of bacteria, has a high computational cost and slow

convergence speed due to its extensive search capability for complex and multi-objective optimization problems.

## 4 Hybrid AI-based techniques

Techniques such as PSO, Fuzzy logic, GWO, and ACO, among others, in artificial intelligence have received considerable attention in research due to their ability to solve complex power quality problems in AC microgrids, among other areas, which are difficult to solve using traditional approaches. To enhance the performance of AI techniques in solving complex real-world problems, hybrid models can be used. Hybrid models assist in overcoming the limitations of traditional AI techniques, and thus, they have become highly popular in the research community [91]. Enhanced Seagull with Rooster Update (ES-RU) Algorithm was developed [92] for adjusting the parameters of the FOPI controller to enhance the performance of UPQC in solving the power quality problems. The combination of these techniques enables the system to handle uncertainties using fuzzy logic and optimize solutions using ACO, thus enhancing the performance of the AC microgrids. The combination of different AI techniques in hybrid models assists in a more effective response to the complex and diverse nature of power quality problems. The rate of convergence of hybrid AI techniques is often faster than that of single-technique approaches. Although there are some limitations in individual AI approaches, such as the tendency of PSO to get stuck in local minima and the difficulty of fuzzy logic

**Table 3.** Power quality improvement using AI techniques.

Ref.	Issues	Mitigation techniques used	Results
[111]	Power quality issues due to active/reactive power changes and grid voltage sag in HRES.	PSO-based PI controllers (offline and online tuning).	Online PSO-based PI controllers reduced ITAE by 15.24% and current THD by 5.32%, achieving the lowest error and THD among the different techniques.
[112]	Power quality issues in a three-phase grid-connected inverter under voltage sag conditions.	PSO-based tuning of PR controller.	PSO-based control parameter tuning produces high-quality output grid voltage and current waveforms, achieving a very low current THD of 0.59% when PR control parameters are tuned using PSO.
[113]	Current control instability in 3-phase PV grid-connected systems under dynamic isolation changes.	PSO-based self-tuning linear current controller with SVPWM.	Achieved fast dynamic response with sinusoidal grid phase voltage and line current. THD was reduced to 0.38%, well below the 5% limit in IEEE Std 1547-2003.
[114]	Power fluctuations and harmonic distortion in microgrid operation during load changes.	PSO-based optimal PI controller for DG units.	Reduced THD from 14.26% (non-optimized) to 11.76%. The system exhibited fewer power fluctuations, improved voltage stability, and faster response.
[40]	Unbalanced and distorted three-phase supply voltages and load currents in a power distribution network.	PSO-based state feedback controller for UPQC.	Maintained THD for source currents and load voltages within permissible limits (<5%) under varying conditions. Improved robustness and performance compared to LQR-based controllers.
[58]	High THD levels in a grid-connected 100 kW PV system under varying solar irradiation.	Fractional Order PI controller tuned using Grey Wolf Optimization (GWO).	THD was reduced to 4.42% at 600 W/m <sup>2</sup> , 2.39% at 800 W/m <sup>2</sup> , and 1.22% at 1000 W/m <sup>2</sup> , meeting IEEE standards (<5%). DC link voltage stabilized at 1450V.
[115]	High harmonic content under non-linear and unbalanced load conditions in a hybrid renewable energy grid-connected system.	Hybrid Shunt Active Power Filter (HSHAPF) optimized with GWO-based Fractional Order PI controller.	THD reduced from 27.43% (without filter) to 1.74% when GWO-tuned HSHAPF is used, with a good power factor improvement.
[116]	High THD in supply current, poor dynamic response in SAPF	ACO-based optimization of PI controller for SAPF	THD was reduced to 3.85%, 2.92%, and 3.49% for phases A, B, and C, respectively. Settling time improved with ACO (287 ms <i>vs.</i> 1140 ms using conventional PI).
[117]	Voltage distortion and high THD in autonomous microgrid	ACO-tuned controller with synchronous reference frame PI control	THD reduced from 35.43% to 4.63%. Voltage regulation improved with V-f control in islanding mode.
[78]	High harmonic distortion and overshoots during DG injection or disconnection; poor power sharing.	Grasshopper Optimization Algorithm (GOA)-based controller.	Compared to the PSO-based controller, the GOA-based controller reduced the overshoot in active power from 180% to 94.4% and load power overshoot from 108.5% to 12.96%, significantly improving dynamic response.
[79]	Harmonic distortion, voltage instability, and reactive power issues in MG due to RES variability.	Adaptive Switched Filter Compensator (ASFC) with GOA-tuned PID controller.	The proposed ASFC achieved a Voltage THD of 1.19% when compared with 3.79% for the traditional SFC, significantly reducing the processing time.
[86]	Voltage and frequency regulation in an autonomous microgrid during load changes and island mode operation.	Bacterial Foraging Optimization Algorithm (BFOA)	The proposed power control strategy successfully regulated the voltage to 220 V and the frequency to 50 Hz after a short transient (voltage regulation achieved after 0.3s, frequency regulation after 0.4s).

in handling high dimensionality, hybrid models can address these issues, resulting in more robust and effective solutions to power quality problems. The scalability of hybrid models of AI makes them suitable for larger systems, as they can easily handle large datasets and complex problem spaces, which are required in large-scale microgrids.

Despite the benefits, hybrid AI approaches are limited by several important constraints. The combination of multiple AI approaches can result in increased computational complexity, which can be time-consuming and require more sophisticated hardware. The combination of multiple AI approaches requires a careful tuning of each component to achieve optimal performance, which can be complex and time-consuming, especially when considering the variety of power quality issues in microgrids. The complexity of hybrid AI approaches can result in higher costs associated with both hardware and software. The computational complexity of hybrid AI approaches can be a challenge for real-time implementation, requiring careful design and optimization to provide timely solutions to power quality problems in microgrids.

#### 4.1 FNN-based controllers

Ji-cheng Liu *et al.* [93] developed a fuzzy neural network model for evaluating the power quality at various observation points in a wind farm. The model uses power quality disturbances to test the safety and stability of wind power in grid connections, with satisfactory results showing high identification accuracy and detail in power quality analysis. The study conducted by Hee-Sang Ko *et al.* [94] presents a fuzzy neural hybrid controller for improving power quality in wind power production plants. The feedforward control employs a neural network inverse model, which is trained with the Levenberg-Marquardt algorithm, and the feedback control is handled by a fuzzy controller. The performance of this controller was significantly better in comparison to the traditional PI and fuzzy controllers in all test cases. In another research, Shixi Hou *et al.* [95] developed a meta-cognitive fuzzy neural network (MCFNN) control strategy for power quality improvement, which has high learning capabilities and excellent performance. The adaptability of MCFNN to parameters and structure makes it suitable for applications involving dynamic loads, and both experimental and simulation studies have proven its efficacy in harmonic compensation.

The application of an Adaptive Fuzzy-Neural-Network (AFNN) controller for improving microgrid power quality using shunt hybrid filters (SHF) was studied by Soumya Ranjan Das *et al.* [96] and compared with adaptive fuzzy sliding (AFS) and adaptive fuzzy back-stepping (AFBS) control strategies. The proposed technique performs better than the existing controllers in demonstrating dynamic performance, stability, and robustness. The AFNN controller ensures fast convergence and low THD, and its performance is analyzed for different solar and wind scenarios. A new control system [97] was developed using an adaptive type-2 fuzzy neural network to enhance power quality. The system employs a model-free design approach using a recurrent feature selection algorithm for type-2 fuzzy neural net-

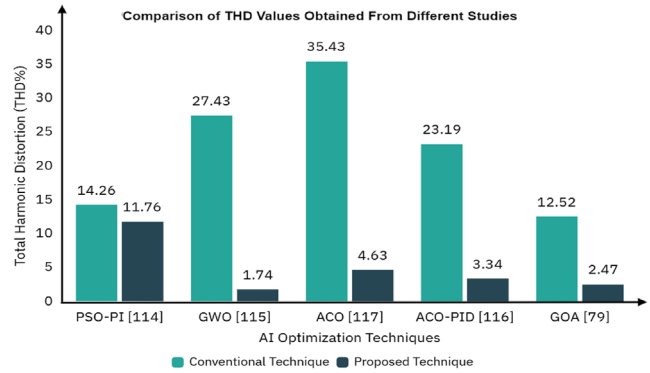

**Figure 10.** Improvement of THD with the help of AI technique ([79, 114–117]).

works. The proposed control strategy retains the robustness and finite-time convergence properties of terminal sliding mode control (TSMC), thus meeting the requirements of practical applications.

S. S. Dheeban *et al.* [98] proposed a PV-UPQC system with an Adaptive Neural Fuzzy Inference System (ANFIS) based controller and reinforcement learning technique for enhancing the power quality in photovoltaic distribution systems. A. Senthil Kumar *et al.* [99] proposed an ANFIS-based adaptive control method to compensate for the distortion in power quality in microgrids connected to power distribution systems using a UPQC device. These works together emphasize the effectiveness of ANFIS-based methods in optimizing the power quality in various grid conditions. The DG with an ANFIS-optimized PI current controller efficiently handles the changes in grid frequency and voltage distortions in nonlinear loads, thus enhancing power quality [100]. The ANFIS-PI optimized DG controller performs better in harmonic compensation, and it can be easily combined with current control methods. B. Rupa *et al.* [101] presented a dual voltage source inverter (DVSI) and dual multilevel converter (DMLC) with an ANFIS-based controller for improving power quality and microgrid performance. The ANFIS controller outperforms conventional fuzzy and ANN controllers in THD analysis, achieving faster stability with a reduced settling time of 0.15 seconds.

The ANFIS with a hysteresis controller was presented in [102] to improve the power quality by using fuzzy interpolation for smooth control and backpropagation of neural networks for adaptability in complex scenarios. The ANFIS controls both the series and shunt active power filters, achieving optimised voltage and current outputs and ultimately improving power quality and stability. Abdelkader *et al.* introduce a DVR system controlled by an ANFIS-based controller that effectively compensates for prolonged power quality issues by integrating a hybrid renewable energy system (HRES) managed with a PI controller. The proposed DVR topology leverages clean energy from solar panels, PEM fuel cells, and battery storage, all connected through DC-DC converters to a DC transmission line. Simulation results indicate a significant improvement in power

**Table 4.** Swarm-based *vs.* hybrid AI for power quality improvement.

Parameter considered	Swarm-based AI methods	Hybrid AI methods
Convergence time	Slower due to extensive exploration	Faster due to improved exploitation
Computational cost	Higher due to more iterations and tuning efforts	Lower due to faster convergence and optimized learning
Scalability	Limited in large-scale MGs due to high computational burden	More scalable, adaptable to large MGs with complex dynamics
Voltage unbalance reduction	Less effective	More effective
THD reduction	Moderate	Significant improvement
Transient response	Slower	Faster
Complexity	Less complex, easy to implement	More complex due to hybridization, but with better performance
Accuracy of optimization	Moderate due to local optima issues	High, better exploration-exploitation balance

quality, with THD in load voltage reduced from 29% to 5% and THD in source current reduced from 30.25% to 2.79% [103]. ANFIS-FOPIDC control was developed [104] for SHAF and UPQC, aiming to minimize the distortions in the current waveform, which improves the performance during load variations and solar irradiation fluctuations.

A neuro-fuzzy UPQC controller was used to reduce voltage imbalances and harmonics in a grid-connected microgrid [105] and achieved a THD of 3.34% in the grid current. Kanata *et al.* [106] used a time-varying nonlinear PSO method, initialized with an artificial neural network (ANN), to optimize reactive power and voltage control in an IEEE 14-bus power system.

Sheila *et al.* [107] proposed a new hybrid GWO-PSO method for solving the reactive power planning problem, thus solving the power quality problem in the grid. Zaid *et al.* [108] studied the application of HPSO-GWO for enhancing the performance of the local control layer under different load and photovoltaic (PV) generation conditions. The method ensures accurate power transfer between the distributed generators (DGs) and proper voltage regulation despite the dynamic conditions. A hybrid PSO-GWO method is proposed for DG planning and provides information on microgrid planning for isolated regions by optimizing grid parameters and enhancing power quality [109].

A hybrid shunt active power filter (HSAPF) optimized using the hybrid PSO-GWO approach and a fractional order proportional-integral-derivative controller (FOPIDC) was proposed by Alok *et al.* [110] for better reactive power and harmonic compensation. A prototype system has been designed, which is cost-effective and easy to implement for the elimination of load-generated harmonics and the achievement of a unity power factor. The FOPIDC-based HSAPF optimized using the hybrid PSO-GWO approach shows better harmonic suppression capabilities for different operating conditions.

The different hybrid AI optimization methods, FNN, ANFIS, PSO-ANN, and PSO-GWO, have been compared based on their convergence speed, computational complexity, scalability, and applicability as presented in Table 2.

FNN and ANFIS have faster convergence speeds because of their adaptive learning properties, with ANFIS being more scalable and applicable for real-time implementation. PSO-ANN achieves low computational cost and effectively handles data and parameter variations, but its performance is sensitive to initial parameter selection, limiting its scalability. PSO-GWO provides a better balance between exploration and exploitation, demonstrating strong robustness, good scalability for complex problems, and reliable performance in real-time environments.

Notable improvements in power quality achieved through various controllers are listed in Table 3. The improvements in THD values obtained using AI techniques are compared with the conventional methods and are shown in Figure 10. Among the proposed optimization techniques shown in Figure 10, optimization using ACO yields the best results in improving THD by 86.9 % when compared with the conventional technique. From Table 4, it is clear that Hybrid AI methods outperform conventional swarm-based techniques in power quality improvement by providing faster convergence, better optimization accuracy, and superior harmonic and voltage compensation.

## 5 Conclusion

This review focuses on swarm intelligence and hybrid AI-based methods to mitigate and improve the power quality of microgrids. AI-based hybrid methods are better than swarm intelligence methods for multiple reasons. These methods can combine the strengths of the traditional methods and address the limitations, like slow convergence or susceptibility to local optima. They also have improved accuracy, robustness, and scalability in solving complex power quality issues. Apart from the complexity of the algorithm involved in integrating two or more optimisation techniques, these methods are highly useful in mitigating the power quality issues. The review indicates that contemporary hybrid-AI methods, which excel in balancing exploration and exploitation, are well-suited for improving power

quality and transient response in microgrids. ANFIS-based methods outperform traditional PI controllers by achieving a significantly lower THD of 3.34% compared to 8.93% and faster stability with a settling time of 0.15 seconds. Similarly, the PSO-ANN hybrid technique minimizes THD to satisfy IEEE-519 norms, decreases active power loss, and further decreases the voltage unbalance factor from 6.93% to 3.44%, which is more efficient than the conventional technique.

However, this research does not cover important areas like hardware integration and the cost or environmental effects associated with it. These areas should be investigated in future studies to gain a complete understanding of the real-time application and integration of these approaches. The extension of hybrid approaches for AI to bigger microgrids and real-time systems will make these approaches more feasible, and this will help them adjust better to changing conditions and improve their performance in real-world power grids. But hardware issues such as sensor compatibility, latency, and high processor costs are associated with AI-based controllers. These issues can be addressed by developing low-latency AI frameworks, improving sensor compatibility, and developing cost-effective hardware solutions for the seamless integration of AI in microgrid applications.

## References

- 1 Hernández-Mayoral E., Madrigal-Martínez M., Mina-Antonio J.D., Iracheta-Cortez R., EnriquezSantiago J.A., Rodríguez-Rivera O., Martínez-Reyes G., Mendoza-Santos E. (2023) A comprehensive review on power-quality issues, optimization techniques, and control strategies of microgrid based on renewable energy sources, *Sustainability* **15**(12), 9847.
- 2 Lasseter, R.H. (2002). MicroGrids, in *2002 IEEE power engineering society winter meeting. Conference proceedings (Cat. No. 02CH37309)*, Vol. **1**, pp. 305–308.
- 3 Nejabatkhah F., Li Y.W. (2014) Overview of power management strategies of hybrid AC/DC microgrid, *IEEE Trans. Power Electron.* **30**(12), 7072–7089.
- 4 Ellabban O., Abu-Rub H., Blaabjerg F. (2014) Renewable energy resources: Current status, prospects and their enabling technology. *Renewable Sustainable Energy Rev.* **39**, 748–764.
- 5 Han Y., Feng Y., Yang P., Xu L., Xu Y., Blaabjerg F. (2019) Cause, classification of voltage sag, and voltage sag emulators and applications: A comprehensive overview, *IEEE Access.* **8**, 1922–1934.
- 6 Natesan C., Ajithan S.K., Palani P., Kandhasamy P. (2014) Survey on microgrid: power quality improvement techniques. *Int. Scholarly Res. Not.* **2014**, 1, 342019.
- 7 Mehta G., Singh S.P. (2013) Power quality improvement through grid integration of renewable energy sources. *IETE J. Res.* **59**, 3, 210–218.
- 8 Kow K.W., Wong Y.W., Rajkumar R.K., Rajkumar R.K. (2016) A review on performance of artificial intelligence and conventional method in mitigating PV grid-tied related power quality events. *Renewable Sustainable Energy Rev.* **56**, 334–346.
- 9 Jou H.L., Wu J.C., Wu K.D., Huang M.S., Lin C.A. (2006) A hybrid compensation system comprising hybrid power filter and AC power capacitor. *Int. J. Electr. Power Energy Syst.* **28**, 7, 448–458.
- 10 Kumarasabapathy N., Manoharan P.S. (2015) MATLAB simulation of UPQC for power quality mitigation using an ant colony based fuzzy control technique. *Sci. World J.* **2015**, 1, 304165.
- 11 Kumar S., Gupta A., Bindal R.K. (2024). Power quality investigation of a grid tied hybrid energy system using a D-STATCOM control and grasshopper optimization technique. *Results Control Optim.* **14**, 100368.
- 12 Girgis A.A., Chang W.B., Makram E.B. (1991) A digital recursive measurement scheme for online tracking of power system harmonics, *IEEE Trans. Power Delivery* **6**, 3, 1153–1160.
- 13 Chen C.L., Lin C.E., Huang C.L. (1994, June) An active filter for unbalanced three-phase system using synchronous detection method, in *Proceedings of 1994 Power Electronics Specialist Conference PESC'94*, IEEE, Vol. **2**, pp. 1451–1455.
- 14 Chen C.L., Lin C.E., Huang C.L. (1994) May. The reference active source current for active power filter in an unbalanced three-phase power system via the synchronous detection method, in *Conference Proceedings. 10th Anniversary. IMTC/94. Advanced Technologies in I & M. 1994 IEEE Instrumentation and Measurement Technology Conference (Cat. No. 94CH3424-9)*, IEEE, pp. 502–505.
- 15 Chaoui A., Gaubert J.P., Krim F., Rambault L. (2008, June) On the design of shunt active filter for improving power quality, in *2008 IEEE International Symposium on Industrial Electronics*, IEEE, pp. 31–37.
- 16 Herrera R.S., Salmerón P., Kim H. (2008) Instantaneous reactive power theory applied to active power filter compensation: Different approaches, assessment, and experimental results. *IEEE Trans. Ind. Electron.* **55**, 1, 184–196.
- 17 Singh B., Al-Haddad K., Chandra A. (1998) A new control approach to three-phase active filter for harmonics and reactive power compensation. *IEEE Trans. Power Syst.* **13**, 1, 133–138.
- 18 Chandra A., Singh B., Singh B.N., Al-Haddad K. (2000) An improved control algorithm of shunt active filter for voltage regulation, harmonic elimination, power-factor correction, and balancing of nonlinear loads. *IEEE Trans. Power Electron.* **15**, 3, 495–507.
- 19 Jain S.K., Agarwal P., Gupta H.O. (2004) A control algorithm for compensation of customer-generated harmonics and reactive power. *IEEE Trans. Power Delivery.* **19**, 1, 357–366.
- 20 Kale M. and Özdemir E. (2005) Harmonic and reactive power compensation with shunt active power filter under non-ideal mains voltage. *Electr. Power Syst. Res.* **74**, 3, 363–370.
- 21 Kunjumammed L.P., Mishra M.K. (2006) A control algorithm for single-phase active power filter under non-stiff voltage source. *IEEE Trans. Power Electron.* **21**, 3, 822–825.
- 22 Chaoui A., Gaubert J.P., Krim F., Champenois G. (2007) PI controlled three-phase shunt active power filter for power quality improvement. *Electr. Power Compon. Syst.* **35**, 12, 1331–1344.
- 23 Patidar R.D., Singh S.P. (2010) Digital signal processor-based shunt active filter controller for customer-generated harmonics and reactive power compensation. *Electr. Power Compon. Syst.* **38**, 8, 937–959.
- 24 Salam Z., Cheng T.P., Jusoh A. (2007) Review of active power filter technologies. *J. Inst. Eng., Malaysia.* **68**, 2, 47–53.
- 25 Das J.C. (2004) Passive filters-potentialities and limitations. *IEEE Trans. Ind. Appl.* **40**, 1, 232–241.

- 26 Singh B., Al-Haddad K., Chandra A. (1999) A review of active filters for power quality improvement. *IEEE Trans. Ind. Electron.* **46**, 5, 960–971.
- 27 Esfahani M.T., Hosseini S.H., Vahidi B. (2015) A new optimal approach for improvement of active power filter using FPSO for enhancing power quality. *Int. J. Electr. Power Energy Syst.* **69**, 188–199.
- 28 Akagi H., Watanabe E.H., Aredes M. (2017). *Instantaneous power theory and applications to power conditioning*, John Wiley & Sons.
- 29 Benachaiba C., Mazari B., Tandjaoui M.N., Haidar A.M. (2016, October) Power quality enhancement using DVR based on ant colony controller, in *2016 57th International Scientific Conference on Power and Electrical Engineering of Riga Technical University (RTUCON)*, IEEE, pp. 1–4.
- 30 Fuchs E.F., Masoum M.A., 2011. *Power quality in power systems and electrical machines*. Academic Press.
- 31 Panigrahi B., Shi Y., Lim M. (2011) *Handbook of Swarm intelligence (adaptation, learning, and optimization)*, Springer-Verlag, Berlin, Germany.
- 32 Coath G., Halgamuge S.K. (2003, December) A comparison of constraint-handling methods for the application of particle swarm optimization to constrained nonlinear optimization problems, in *The 2003 Congress on Evolutionary Computation, 2003. CEC'03*, IEEE, Vol. 4, pp. 2419–2425.
- 33 Arya L.D., Titare L.S., Kothari D.P. (2010) Improved particle swarm optimization applied to reactive power reserve maximization. *Int. J. Electr. Power Energy Syst.* **32**, 5, 368–374.
- 34 Das S. R., Mishra A. K., Ray P. K., Salkuti S. R., Kim S.-C. (2022) Application of artificial intelligent techniques for power quality improvement in hybrid microgrid system. *Electronics*. **11**, 22, 3826.
- 35 Del Valle Y., Venayagamoorthy G.K., Mohagheghi S., Hernandez J.C., Harley R.G. (2008) Particle swarm optimization: basic concepts, variants and applications in power systems. *IEEE Trans. Evol. Comput.* **12**, 2, 171–195.
- 36 Mahela O.P., Shaik A.G. (2016). Topological aspects of power quality improvement techniques: A comprehensive overview. *Renewable Sustainable Energy Rev.* **58**, 1129–1142.
- 37 Kumar R., Sinha A.K. (2012, December) Unified power quality conditioner controller for enhancement of power system voltage stability using state vector modulation, in *2012 Annual IEEE India Conference (INDICON)*, IEEE, pp. 891–896.
- 38 Kabir M.A., Mahub U. (2011) February. Synchronous detection and digital control of shunt active power filter in power quality improvement, in *2011 IEEE Power and Energy Conference at Illinois*, IEEE, pp. 1–5.
- 39 Bhargavi R.N. (2011, May) Power quality improvement: Using interline unified power quality conditioner, in *2011 10th International Conference on Environment and Electrical Engineering*, IEEE, pp. 1–5.
- 40 Karanki S.B., Mishra M.K., Kumar B.K. (2010) Particle swarm optimization-based feedback controller for unified power-quality conditioner. *IEEE Trans. Power Delivery.* **25**, 4, 2814–2824.
- 41 Ketzner M.B., Jacobina C.B. (2014, December) Sensorless current shaping control technique for shunt active filters, in *2014 11th IEEE/IAS International Conference on Industry Applications*, IEEE, pp. 1–7.
- 42 Gotherwal N., Ray S., Gupta N., Saxena D. (2016, July) Performance comparison of PI and fuzzy controller for indirect current control based shunt active power filter, in *2016 IEEE 1st International Conference on Power Electronics, Intelligent Control and Energy Systems (ICPEICES)*, IEEE, pp. 1–6.
- 43 Tarisciotti L., Formentini A., Gaeta A., Degano M., Zanchetta P., Rabbeni R., Pucci M. (2016) Model predictive control for shunt active filters with fixed switching frequency. *IEEE Trans. Ind. Appl.* **53**, 1, 296–304.
- 44 Biricik S., Komurcugil H. (2016) Three-level hysteresis current control strategy for three-phase four-switch shunt active filters. *IET Power Electron.* **9**, 8, 1732–1740.
- 45 Tilli A., Conficoni C. (2015) Control of shunt active filters with actuation and current limits. *IEEE Trans. Control Syst. Technol.* **24**, 2, 644–653.
- 46 Ronchi F., Tilli A., Marconi L. (2003, September) Control of shunt active filter based on the internal model principle: Tuning procedure and experimental results, in *2003 European Control Conference (ECC)*, IEEE, pp. 2327–2332.
- 47 Panigrahi R., Subudhi B. (2016) Performance enhancement of shunt active power filter using a Kalman filter-based H $\infty$  control strategy. *IEEE Trans. Power Electron.* **32**, 4, 2622–2630.
- 48 Bhattacharya S., Cheng P.T., Divan D.M. (1997) Hybrid solutions for improving passive filter performance in high power applications. *IEEE Trans. Ind. Appl.* **33**, 3, 732–747.
- 49 Shukla S., Mishra S., Singh B., Kumar S. (2017) Implementation of empirical mode decomposition based algorithm for shunt active filter. *IEEE Trans. Ind. Appl.* **53**, 3, 2392–2400.
- 50 Ko H., Gu J.C. (2016) Impact of shunt active harmonic filter on harmonic current distortion of voltage source inverter-fed drives. *IEEE Trans. Ind. Appl.* **52**, 4, 2816–2825.
- 51 Mane M., Namboothiripad M.K. (2016, January) Current harmonics reduction using sliding mode control based shunt active power filter, in *2016 10th International Conference on Intelligent Systems and Control (ISCO)*, IEEE, pp. 1–6.
- 52 Hao S., Fu Z., Wang Q., Zheng J., Zhang M. (2016, July) A novel control strategy for shunt active power filter under nonlinear and unbalanced three phase load conditions, in *2016 International Symposium on Computer, Consumer and Control (IS3C)*, IEEE, pp. 96–98.
- 53 Gowtham N., Shankar S. (2016) February. PI tuning of Shunt Active Filter using GA and PSO algorithm, in *2016 2nd International Conference on Advances in Electrical, Electronics, Information, Communication and Bio-Informatics (AEEICB)*, IEEE, pp. 207–213.
- 54 Kumar R., Bansal H.O., Gautam A.R., Mahela O.P., Khan B. (2022) Experimental investigations on particle swarm optimization based control algorithm for shunt active power filter to enhance electric power quality. *IEEE Access.* **10**, 54878–54890.
- 55 Swief R.A., Abdel-Salam T.S. (2017, December) PV impact on distribution system performance following grey wolf algorithm, in *2017 Nineteenth International Middle East Power Systems Conference (MEPCON)*, IEEE, pp. 437–444
- 56 Mirjalili S., Mirjalili S.M., Lewis A. (2014) Grey wolf optimizer. *Adv. Eng. Software.* **69**, 46–61.
- 57 Mishra A.K., Das S.R., Ray P.K., Mallick R.K., Mohanty A., Mishra D.K. (2020) PSO-GWO optimized fractional order PID based hybrid shunt active power filter for power quality improvements. *IEEE Access.* **8**, 74497–74512.
- 58 Gupta M., Gakhar P. (2019) Power quality improvement in a grid coupled solar PV system using grey wolf optimization. *Int. J. Innov. Technol. Explor. Eng.* **8**, 3200–3204.

- 59 Goud B.S., Rami Reddy C., Naga Sai, Kalyan C., Udumula R.R., Bajaj M., Abdul Samad B., Shouran M., Kamel S. (2022) PV/WT integrated system using the Gray Wolf Optimization Technique for power quality improvement. *Front. Energy Res.* **10**, 957971.
- 60 Rajagopal V., Sharath D., Vishwas G., Bangarraju J., Arya S.R., Venkatesh C. (2022) Optimized controller gains using grey wolf algorithm for grid tied solar power generation with improved dynamics and power quality. *Chin. J. Electr. Eng.* **8**, 2, 75–85.
- 61 Ravi T., Kumar K.S. (2023) Detection and classification of power quality disturbances using stock well transform and improved grey wolf optimization-based kernel extreme learning machine. *IEEE Access.* **11**, 61710–61727.
- 62 Dorigo M., Birattari M., Stutzle T. (2006) Ant colony optimization. *IEEE Comput. Intell. Mag.* **1**, 4, 28–39.
- 63 Trivedi I.N., Thesiya D.K., Esmat A., Jangir P. (2015, August) A multiple environment dispatch problem solution using ant colony optimization for micro-grids, in *2015 international conference on power and advanced control engineering (ICPACE)*, IEEE, pp. 109–115.
- 64 Li D., Wang T., Pan W., Ding X., Gong J. (2021) A comprehensive review of improving power quality using active power filters. *Electr. Power Syst. Res.* **199**, 107389.
- 65 Gali V., Gupta N., Gupta R.A. 2017 “Mitigation of power quality problems using shunt active power filters: A comprehensive review,” *2017 12th IEEE Conference on Industrial Electronics and Applications (ICIEA)*. Siem Reap, Cambodia, pp. 1100–1105. <https://doi.org/10.1109/ICIEA.2017.8283004>.
- 66 Routimo M., Salo M., Tuusa H. (2007) Comparison of voltage-source and current-source shunt active power filters. *IEEE Trans. Power Electron.* **22**, 2, 636–643.
- 67 Singh B., Al-Haddad K., Chandra A. (1999) A review of active filters for power quality improvement. *IEEE Trans. Ind. Electron.* **46**, 5, 960–971.
- 68 Singh, A.C., Kamal Al-Haddad B. (1999) Computer-aided modeling and simulation of active power filters. *Electric Mach. Power Syst.* **27**, 11, 1227–1241.
- 69 Jou H.L., Wu K.D., Wu J.C., Li C.H., Huang M.S. (2008) Novel power converter topology for three-phase four-wire hybrid power filter. *IET Power Electron.* **1**, 1, 164–173.
- 70 Tiwari A.K., Dubey S.P. (2016, March) Ant colony optimization based hybrid active power filter for harmonic compensation, in *2016 International Conference on Electrical, Electronics, and Optimization Techniques (ICEEOT)*, IEEE, pp. 777–782.
- 71 Meraihi Y., Gabis A.B., Mirjalili S., Ramdane-Cherif A. (2021) Grasshopper optimization algorithm: theory, variants, and applications. *IEEE Access.* **9**, 50001–50024.
- 72 Saremi S., Mirjalili S., Lewis A. (2017) Grasshopper optimization algorithm: Theory and application. *Adv. Eng. Software.* **105**, 30–47.
- 73 Steczek M., Jefimowski W., Szeląg A. (2020) Application of grasshopper optimization algorithm for selective harmonics elimination in low-frequency voltage source inverter. *Energies.* **13**, 23, 6426.
- 74 Yadav S., Yadav R., Kumar A., Kumar M. (2021) A novel approach for optimal design of digital FIR filter using grasshopper optimization algorithm. *ISA Trans.* **108**, 196–206.
- 75 Sahu P.R., Hota P.K., Panda S. (2018, December) Comparison of grasshopper and whale optimization algorithm for design of FACTS controller with power system stabilizer, in *2018 fifth international conference on parallel, distributed and grid computing (PDGC)*, IEEE, pp. 424–429.
- 76 Amin M.N., Soliman M.A., Hasanien H.M., Abdelaziz A.Y. (2020) Grasshopper optimization algorithm-based PI controller scheme for performance enhancement of a grid-connected wind generator. *J. Control, Autom. Electr. Syst.* **31**, 393–401.
- 77 Annamraju A., Nandiraju S. (2018, December) Frequency control in an autonomous two-area hybrid microgrid using grasshopper optimization based robust PID controller, in *2018 8th IEEE India International Conference on Power Electronics (IICPE)*, IEEE, pp. 1–6.
- 78 Jumani T.A., Mustafa M.W., Md Rasid M., Hussain Mirjat N., Hussain Baloch M., Salisu S., (2019) Optimal power flow controller for grid-connected microgrids using grasshopper optimization algorithm. *Electronics* **8**, 1, 111.
- 79 Elmetwaly A.H., Eldesouky A.A., Sallam A.A. (2020) An adaptive D-FACTS for power quality enhancement in an isolated microgrid. *IEEE Access.* **8**, 57923–57942.
- 80 Jumani T.A., Mustafa M.W., Md Rasid M., Mirjat N.H., Leghari Z.H., Saeed M.S. (2018) Optimal voltage and frequency control of an islanded microgrid using grasshopper optimization algorithm. *Energies.* **11**, 11, 3191.
- 81 Abdulwahab I., Olaniyan A.A., Musa U., Ajayi O.O. (2021) Optimization of a droop controlled micro-grid using grasshopper optimization algorithm. *Zaria J.* **10**, 1, 65.
- 82 Passino K.M. (2002) Biomimicry of bacterial foraging for distributed optimization and control. *IEEE Control Syst. Mag.* **22**, 3, 52–67.
- 83 Fogel D.B. (1998) *Artificial intelligence through simulated evolution*, Wiley-IEEE Press, 227–296.
- 84 Mishra S. (2005) A hybrid least square-fuzzy bacterial foraging strategy for harmonic estimation. *IEEE Trans. Evol. Comput.* **9**, 1, 61–73.
- 85 Arijit B., Sambarta D., Swagatarn D. (2007) A synergy of differential evolution and bacterial foraging algorithm for global optimization. *Neural Network World.* **17**, 6, 607–626.
- 86 Chitra N., Senthil Kumar A., Priyadharshini P., Shobana K.M. (2015) Control strategy for PQ improvement in an autonomous microgrid using bacterial foraging optimization algorithm, in *Artificial Intelligence and Evolutionary Algorithms in Engineering Systems: Proceedings of ICAEES 2014*. Springer India, Volume 2, pp. 705–713.
- 87 Biswas A., Dasgupta S., Das S., Abraham A. (2007) Synergy of PSO and bacterial foraging optimization – a comparative study on numerical benchmarks. *Innovations Hybrid Intell. Syst.*, 255–263.
- 88 Othman A.M., Gabbar H.A. (2017) Enhanced microgrid dynamic performance using a modulated power filter based on enhanced bacterial foraging optimization. *Energies.* **10**, 6, 776.
- 89 Dubuisson F., Rezkallah M., Ibrahim H., Chandra A. (2021) Real-time implementation of the predictive-based control with bacterial foraging optimization technique for power management in standalone microgrid application. *Energies.* **14**, 6, 1723.
- 90 Tang W.J., Li M.S., Wu Q.H., Saunders J.R., (2008) Bacterial foraging algorithm for optimal power flow in dynamic environments. *IEEE Trans. Circuits Syst. I: Regul. Pap.* **55**, 8, 2433–2442.
- 91 Vidhya K., Krishnamoorthi K. (2022) A hybrid technique for optimal power quality enhancement in grid-connected photovoltaic interleaved inverter. *Energy Environ.* **35**, 1, 244–274. <https://doi.org/10.1177/0958305X221140574>

- 92 Yadav S.K., Yadav K.B., Priyadarshi A. (2024) Performance analysis of three-phase solar PV, BESS, and Wind integrated UPQC for power quality improvement. *Comput. Electr. Eng.* **116**, 109230.
- 93 Liu J., Jing Y., Shi F., Cai N. (2017) Research on power quality evaluation of wind farm based on fuzzy neural network J. *Int. J. Multimedia Ubiquitous Eng.* **12**, 4, 109116.
- 94 Ko H.S., Lee K.Y., Kang M.J., Kim H.C. (2008) Power quality control of an autonomous wind– diesel power system based on hybrid intelligent controller. *Neural Networks.* **21**, 10, 1439–1446.
- 95 Hou S., Chu Y., Fei J. (2020) Modified fuzzy neural network control using sliding mode technique for power quality improvement system with experimental verification. *IET Control Theory Appl.* **14**, 19, 3029–3037.
- 96 Das S.R., Ray P.K., Sahoo A.K., Singh K.K., Dhiman G., Singh A. (2021) Artificial intelligence based grid connected inverters for power quality improvement in smart grid applications. *Comput. Electr. Eng.* **93**, 107208.
- 97 Hou S., Chu Y., Fei J. (2021) Adaptive type-2 fuzzy neural network inherited terminal sliding mode control for power quality improvement. *IEEE Trans. Ind. Inf.* **17**, 11, 7564–7574.
- 98 Dheeban S.S., Muthu Selvan N.B. (2023) ANFIS-based power quality improvement by photovoltaic integrated UPQC at distribution system. *IETE J. Res.* **69**, 5, 2353–2371.
- 99 Kumar A.S., Rajasekar S., Raj P.A.D.V. (2015) Power quality profile enhancement of utility connected microgrid system using ANFIS-UPQC. *Procedia Technol.* **21**, 112–119.
- 100 Bilgundi S.K., Sachin R., Pradeepa H., Nagesh H.B., Kumar M.L. (2022) Grid power quality enhancement using an ANFIS optimized PI controller for DG. *Prot. Control Mod. Power Syst.* **7**, 1, 1–14.
- 101 Rupa B., Manohar J.N., Manjula M. (2023) Power quality improvement using dual multilevel converter for micro grid-connected PV energy systems using ANFIS. *Int. J. Electr. Electron. Res.* **11**, 550558.
- 102 Manivasagam R., Prabakaran R. (2020) Power quality improvement by UPQC using ANFIS-based hysteresis controller. *Int. J. Oper. Res.* **37**, 2, 174–197.
- 103 Abdelkader A.B., Mouloudi Y., Soumeur M.A. (2023) Integration of renewable energy sources in the dynamic voltage restorer for improving power quality using ANFIS controller. *J. King Saud Univ.-Eng. Sci.* **35**, 8, 539–548.
- 104 Srilakshmi K., Kondreddi K., Ramadevi A., Mumiraj R., Vangalapudi R. (2025). Grid connected and standalone renewable source fed UPQC: A hybrid control technique for power quality enhancement. *Discover Appl. Sci.* **7**, 3, 147.
- 105 Renduchintala U.K., Pang C. (2016, May) Neuro-fuzzy based UPQC controller for Power Quality improvement in micro grid system, in *2016 IEEE/PES Transmission and Distribution Conference and Exposition (T&D)*, IEEE, pp. 1–5).
- 106 Kanata S., Sianipar G.H., Maulidevi N.U. (2018, April) Optimization of reactive power and voltage control in power system using hybrid artificial neural network and particle swarm optimization, in *2018 2nd International Conference on Applied Electromagnetic Technology (AEMT)*, IEEE, pp. 67–72.
- 107 Mahapatra S., Badi M., Raj S. (2019, October) Implementation of PSO, it's variants and Hybrid GWO-PSO for improving Reactive Power Planning, in *2019 Global Conference for Advancement in Technology (GCAT)*, IEEE, pp. 1–6.
- 108 Al-Tameemi Z.H.A., Lie T.T., Foo G., Blaabjerg F. (2022) Optimal coordinated control of DC microgrid based on hybrid PSO–GWO algorithm. *Electricity.* **3**, 3, 346–364.
- 109 Suman G.K., Guerrero J.M., Roy O.P. (2021) Optimisation of solar/wind/bio- generator/diesel/battery based microgrids for rural areas: A PSO-GWO approach. *Sustainable Cities Soc.* **67**, 102723.
- 110 Mishra A.K., Das S.R., Ray P.K., Mallick R.K., Mohanty A., Mishra D.K. (2020) PSO-GWO optimized fractional order PID based hybrid shunt active power filter for power quality improvements. *IEEE Access.* **8**, 74497–74512.
- 111 García-Triviño P., Gil-Mena A.J., Llorens-Iborra F., García-Vázquez C.A., Fernández-Ramírez L.M., Jurado F. (2015) Power control based on particle swarm optimization of grid-connected inverter for hybrid renewable energy system. *Energy Convers. Manage.* **91**, 83–92
- 112 Althobaiti A., Armstrong M., Elgendy M.A. (2016, April) Control parameters optimization of a three-phase grid-connected inverter using particle swarm optimisation, in *8th IET International Conference on Power Electronics, Machines and Drives (PEMD 2016)*. IET, pp. 1–6.
- 113 Al-Saedi W., Lachowicz S.W., Habibi D. (2011, September) An optimal current control strategy for a three-phase grid-connected photovoltaic system using Particle Swarm Optimization, in *2011 IEEE Power Engineering and Automation Conference*, IEEE, Vol. 1, pp. 286–290.
- 114 Moghimi S.M., Shariatmadar S.M., Dashti R. (2016) Active-reactive power stability analysis a micro grid in grid to connected mode based on particle swarm optimization (PSO) including model information. *Phys. Sci. Int. J.* **10**, 2).
- 115 Goud B.S., Rami Reddy C., Naga Sai Kalyan C., Udumula R.R., Bajaj M., Abdul Samad B., Shouran M., Kamel S. 2022 PV/WT integrated system using the Gray Wolf Optimization Technique for power quality improvement. *Front. Energy Res.* **10**, 957971.
- 116 Sakthivel A., Vijayakumar P., Senthilkumar A., Lakshminarasimman L., Paramasivam S. (2015) Experimental investigations on ant colony optimized PI control algorithm for shunt active power filter to improve power quality. *Control Eng. Pract.* **42**, 153–169.
- 117 Chitra N., Prabaakaran K., Kumar A.S., Munda J. (2013) Ant colony optimization adopting control strategies for power quality enhancement in autonomous microgrid. *Int. J. Comput. Appl.* **63**, 13.